

BUNN®

G9-2T DBC
for use
with Smart Funnel®

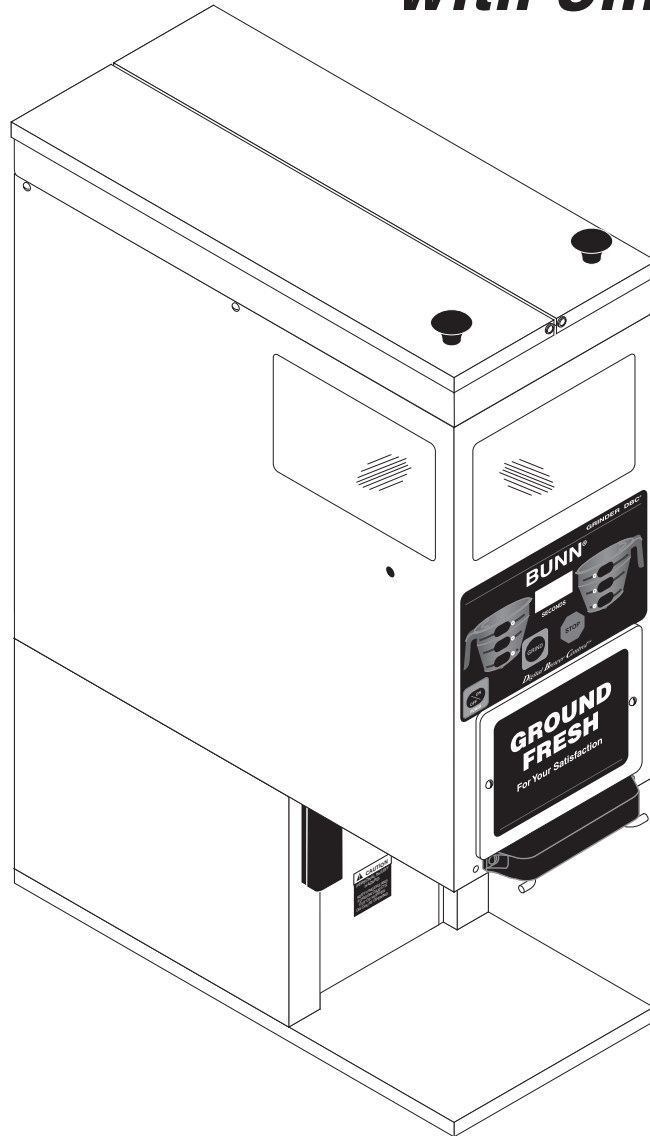

ILLUSTRATED PARTS CATALOG

Designs, materials, weights, specifications, and dimensions for equipment or replacement parts are subject to change without notice.

BUNN-O-MATIC CORPORATION

POST OFFICE BOX 3227

SPRINGFIELD, ILLINOIS 62708-3227

PHONE: (217) 529-6601 FAX: (217) 529-6644



BUNN-O-MATIC COMMERCIAL PRODUCT WARRANTY

Bunn-O-Matic Corp. ("BUNN") warrants equipment manufactured by it as follows:

- 1) Airpots, thermal carafes, decanters, GPR servers, iced tea/coffee dispensers, MCP/MCA pod brewers thermal servers and Thermofresh servers (mechanical and digital)- 1 year parts and 1 year labor.
- 2) All other equipment - 2 years parts and 1 year labor plus added warranties as specified below:
 - a) Electronic circuit and/or control boards - parts and labor for 3 years.
 - b) Compressors on refrigeration equipment - 5 years parts and 1 year labor.
 - c) Grinding burrs on coffee grinding equipment to grind coffee to meet original factory screen sieve analysis - parts and labor for 4 years or 40,000 pounds of coffee, whichever comes first.

These warranty periods run from the date of installation BUNN warrants that the equipment manufactured by it will be commercially free of defects in material and workmanship existing at the time of manufacture and appearing within the applicable warranty period. This warranty does not apply to any equipment, component or part that was not manufactured by BUNN or that, in BUNN's judgment, has been affected by misuse, neglect, alteration, improper installation or operation, improper maintenance or repair, non periodic cleaning and descaling, equipment failures related to poor water quality, damage or casualty. In addition, the warranty does not apply to replacement of items subject to normal use including but not limited to user replaceable parts such as seals and gaskets. This warranty is conditioned on the Buyer 1) giving BUNN prompt notice of any claim to be made under this warranty by telephone at (217) 529-6601 or by writing to Post Office Box 3227, Springfield, Illinois 62708-3227; 2) if requested by BUNN, shipping the defective equipment prepaid to an authorized BUNN service location; and 3) receiving prior authorization from BUNN that the defective equipment is under warranty.

THE FOREGOING WARRANTY IS EXCLUSIVE AND IS IN LIEU OF ANY OTHER WARRANTY, WRITTEN OR ORAL, EXPRESS OR IMPLIED, INCLUDING, BUT NOT LIMITED TO, ANY IMPLIED WARRANTY OF EITHER MERCHANTABILITY OR FITNESS FOR A PARTICULAR PURPOSE. The agents, dealers or employees of BUNN are not authorized to make modifications to this warranty or to make additional warranties that are binding on BUNN. Accordingly, statements by such individuals, whether oral or written, do not constitute warranties and should not be relied upon.

If BUNN determines in its sole discretion that the equipment does not conform to the warranty, BUNN, at its exclusive option while the equipment is under warranty, shall either 1) provide at no charge replacement parts and/or labor (during the applicable parts and labor warranty periods specified above) to repair the defective components, provided that this repair is done by a BUNN Authorized Service Representative; or 2) shall replace the equipment or refund the purchase price for the equipment.

THE BUYER'S REMEDY AGAINST BUNN FOR THE BREACH OF ANY OBLIGATION ARISING OUT OF THE SALE OF THIS EQUIPMENT, WHETHER DERIVED FROM WARRANTY OR OTHERWISE, SHALL BE LIMITED, AT BUNN'S SOLE OPTION AS SPECIFIED HEREIN, TO REPAIR, REPLACEMENT OR REFUND.

In no event shall BUNN be liable for any other damage or loss, including, but not limited to, lost profits, lost sales, loss of use of equipment, claims of Buyer's customers, cost of capital, cost of down time, cost of substitute equipment, facilities or services, or any other special, incidental or consequential damages.

392, A Partner You Can Count On, AutoPOD, AXIOM, BrewLOGIC, BrewMETER, Brew Better Not Bitter, BrewWISE, BrewWIZARD, BUNN Espresso, BUNN Family Gourmet, BUNN Gourmet, BUNN Pour-O-Matic, BUNN, BUNN with the stylized red line, BUNNlink, Bunn-OMatic, Bunn-O-Matic, BUNNserve, BUNNSERVE with the stylized wrench design, Cool Froth, DBC, Dr. Brew stylized Dr. design, Dual, Easy Pour, EasyClear, EasyGard, FlavorGard, Gourmet Ice, Gourmet Juice, High Intensity, iMIX, Infusion Series, Intellisteam, My Café, Phase Brew, PowerLogic, Quality Beverage Equipment Worldwide, Respect Earth, Respect Earth with the stylized leaf and coffee cherry design, Safety-Fresh, savemycoffee.com, Scale-Pro, Silver Series, Single, Smart Funnel, Smart Hopper, SmartWAVE, Soft Heat, SplashGard, The Mark of Quality in Beverage Equipment Worldwide, ThermoFresh, Titan, trifecta, Velocity Brew, Air Brew, Air Infusion, Beverage Bar Creator, Beverage Profit Calculator, Brew better, not bitter., BUNNSource, Coffee At Its Best, Cyclonic Heating System, Daypart, Digital Brewer Control, Element, Nothing Brews Like a BUNN, Pouring Profits, Signature Series, Tea At Its Best, The Horizontal Red Line, Ultra are either trademarks or registered trademarks of Bunn-O-Matic Corporation. The commercial trifecta® brewer housing configuration is a trademark of Bunn-O-Matic Corporation.

TABLE OF CONTENTS

Title	Page No.
Electrical Controls	16
Hopper, Lid and Slide Plate Assy.....	8
Housing, Base and Panels.....	4
Motor, Burr Housing and Mounting Plate.....	12
Numerical Index.....	18

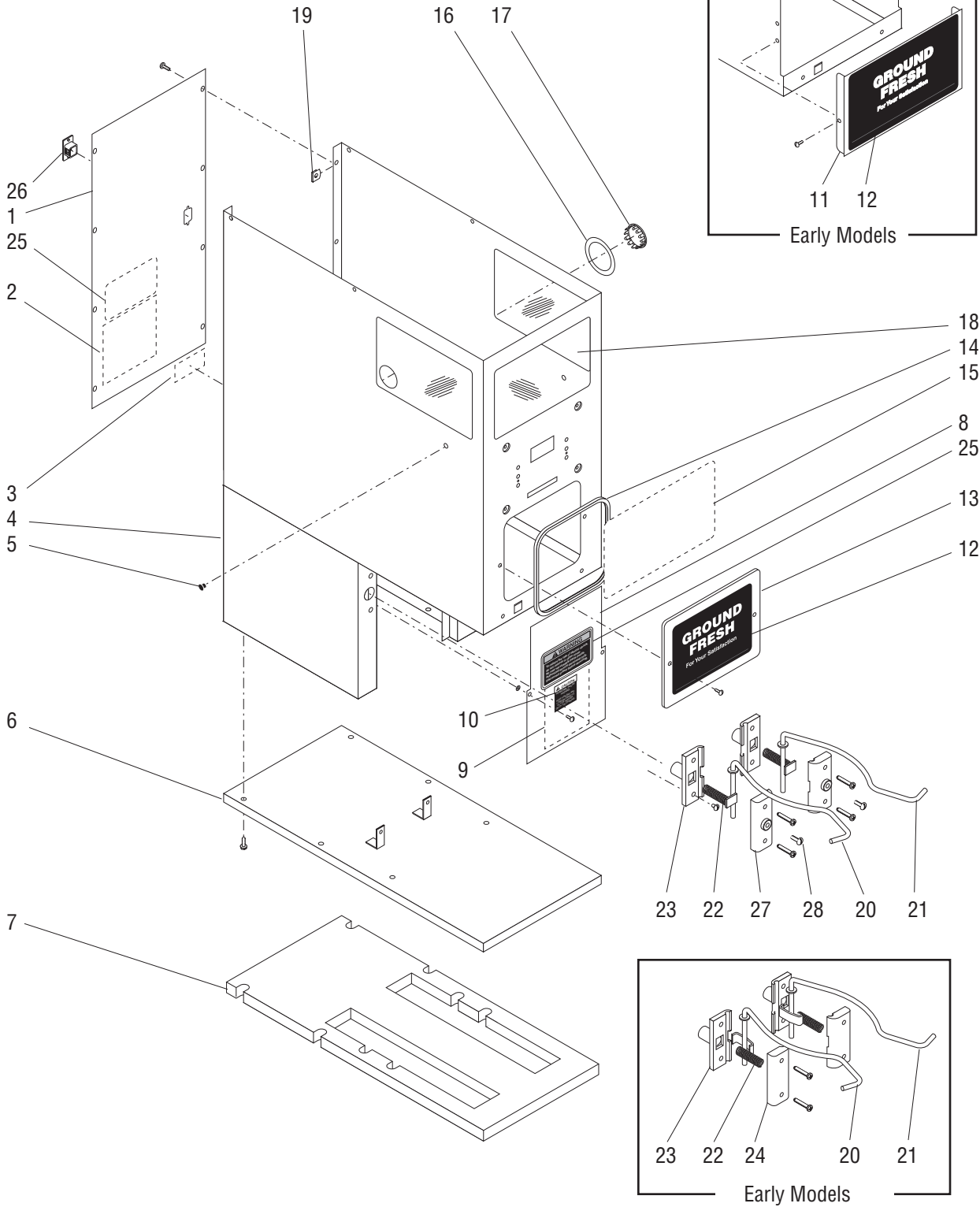

HOUSING, BASE AND PANELS

ITEM	PART NO.	QTY.	DESCRIPTION
1	37966.1000	1	Rear Panel W/Decal SST (Includes item 2)
	37966.1001	1	Rear Panel W/Decal BLK (Includes item 2)
	01315.0000	8	Screw, Truss Head SST #8-32 x .38"
	02322.0002	8	Screw, Truss Head BLK #8-32 x .38"
2	20545.0000	1	Decal, Warning Electrical
3	24237.0000	1	Decal, Notice - Interface Voltage
4	33739.0000	1	Housing Assy W/Decals, SST (Includes items 3,14 & 16)
	38170.1001	1	Housing Assy W/Decals, BLK (Includes items 14 & 16)
5	05921.0000	2	Plug, Hole .25" Dia. (Early Models)
6	05752.0000	1	Base SST
	05752.0001	1	Base BLK
	02311.0000	6	Screw, Hex Crimptite #10-32 x .50"
7	05816.0000	1	Pad, Base
8	33732.1000	1	Panel Assy W/Decals, SST (Includes hardware below and items 9, 10 & 25)
	33732.1001	1	Panel Assy W/Decals, BLK (Includes hardware below and items 9, 10 & 25)
	01380.0000	2	Screw, Truss Head SST #6-32 x .50"
	01382.0002	2	Screw, Truss Head BLK #6-32 x .50"
	01518.0000	2	Washer, Screw Retaining #6
9	33734.0000	1	Schematic 120V & 230V
10	05876.0000	1	Decal, Caution
11	33733.1000	1	Cover Assy W/Decal SST (Includes item 12)
	33733.1001	1	Cover Assy W/Decal BLK (Includes item 12)
	01380.0000	2	Screw, Truss Head #6-32 x .50"
12	33735.0000	1	Decal, Ground Fresh (Early Models)
	33735.0002	1	Decal, Ground Fresh (Late Models)
13	05838.1000	1	Cover w/Decal, SST (Includes item 12)
	05838.1001	1	Cover w/Decal, BLK (Includes item 12)
	01380.0000	2	Screw, Truss Head SST #6-32 x .50"
	01382.0002	2	Screw, Truss Head BLK #6-32 x .50"
	01518.0000	2	Washer, Screw Retaining #6
14	-----	1	Edging 19.15" (order item 31)
15	-----	1	Membrane Switch (See ELECTRICAL CONTROLS)
16	05884.0000	1	Decal, Motor Reset
17	02999.0000	1	Plug, Hole SST 1.19" Dia.
	25126.0000	1	Plug, Hole BLK 1.19" Dia.
18	05814.0001	3	Window Assy (Includes adhesive)
19	00917.0000	8	Clip, J-Type #8-32
20	32568.0000	1	Funnel Rail, Left (Early Models, Non-Adjustable)
	32568.0001	1	Funnel Rail, Left (Late Models, Adjustable)
21	32569.0000	1	Funnel Rail, Right (Early Models, Non-Adjustable)
	32569.0001	1	Funnel Rail, Right (Late Models, Adjustable)

} Early Models

} Late Models

(Continued)

* Indicates the part number listed is for reference only. See DESCRIPTION for possible service replacement.

(Continued)

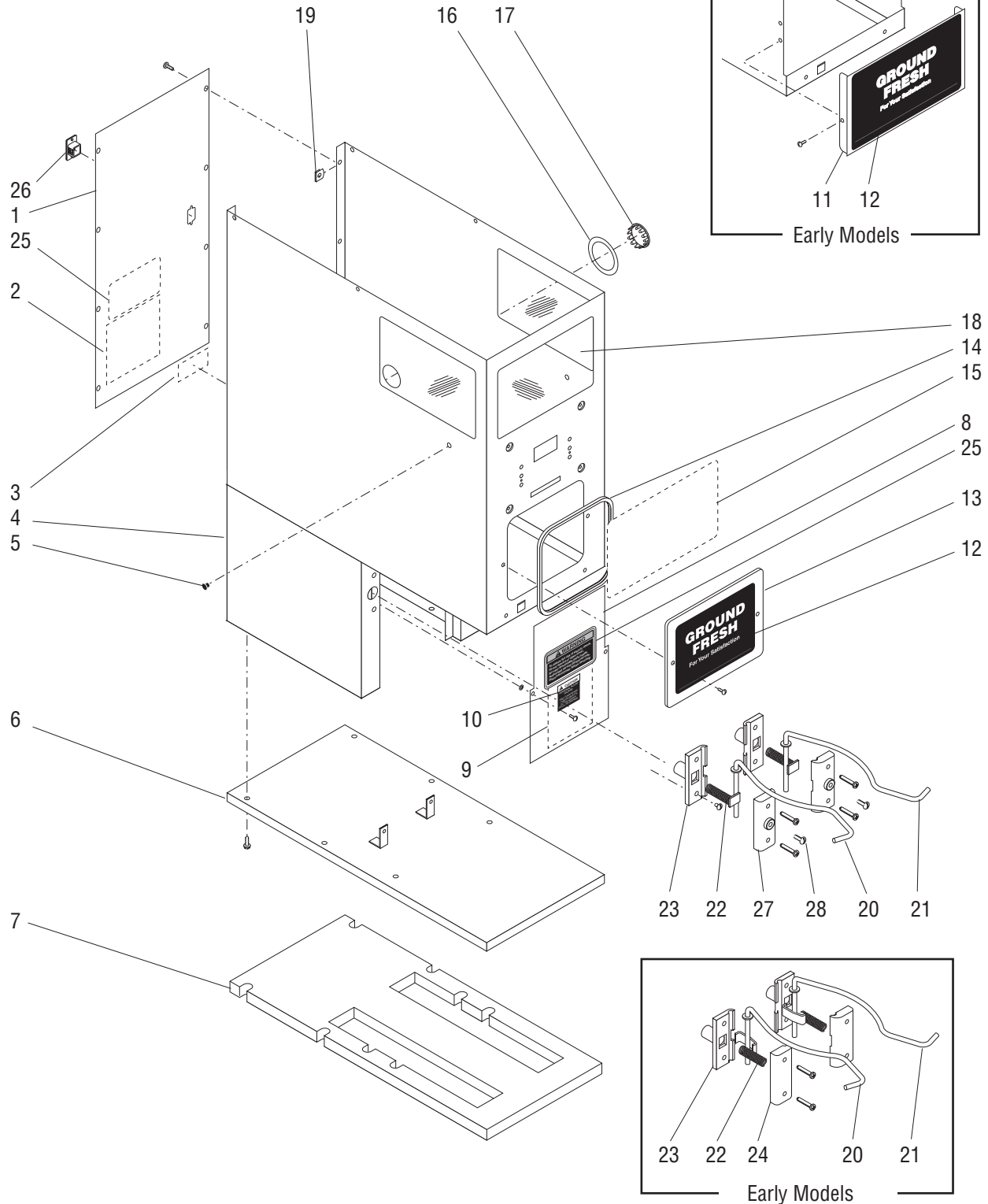

HOUSING, BASE AND PANELS

ITEM	PART NO.	QTY.	DESCRIPTION
22	32570.0000	2	Spring
23	32561.0000	2	Bracket, Inner Spring
24	32562.0001*	2	Bracket, Outer Spring
	01326.0008	4	Screw, Truss Head, Blk #10-32 x 1.25"
25	37881.0000	2	Decal, No Serviceable Parts
26	36398.0000	1	Plug, DB9 (Early Models)
27	39586.1000	2	Bracket, Outer Spring (Late Models, Adjustable)
	01326.0008	4	Screw, Truss Head, BLK #10-32 x 1.25"
28	01317.0000	2	Screw, Adjustment, Truss Head, BLK #10-32 x .50"
29	00879.0000	1	Decal, Decaffeinated Coffee
30	05940.0000	1	Decal, Orange Dot
31	38278.1002	-	Edging 36.0" (Cut to required length)

} Not Illustrated

* Indicates the part number listed is for reference only. See DESCRIPTION for possible service replacement.

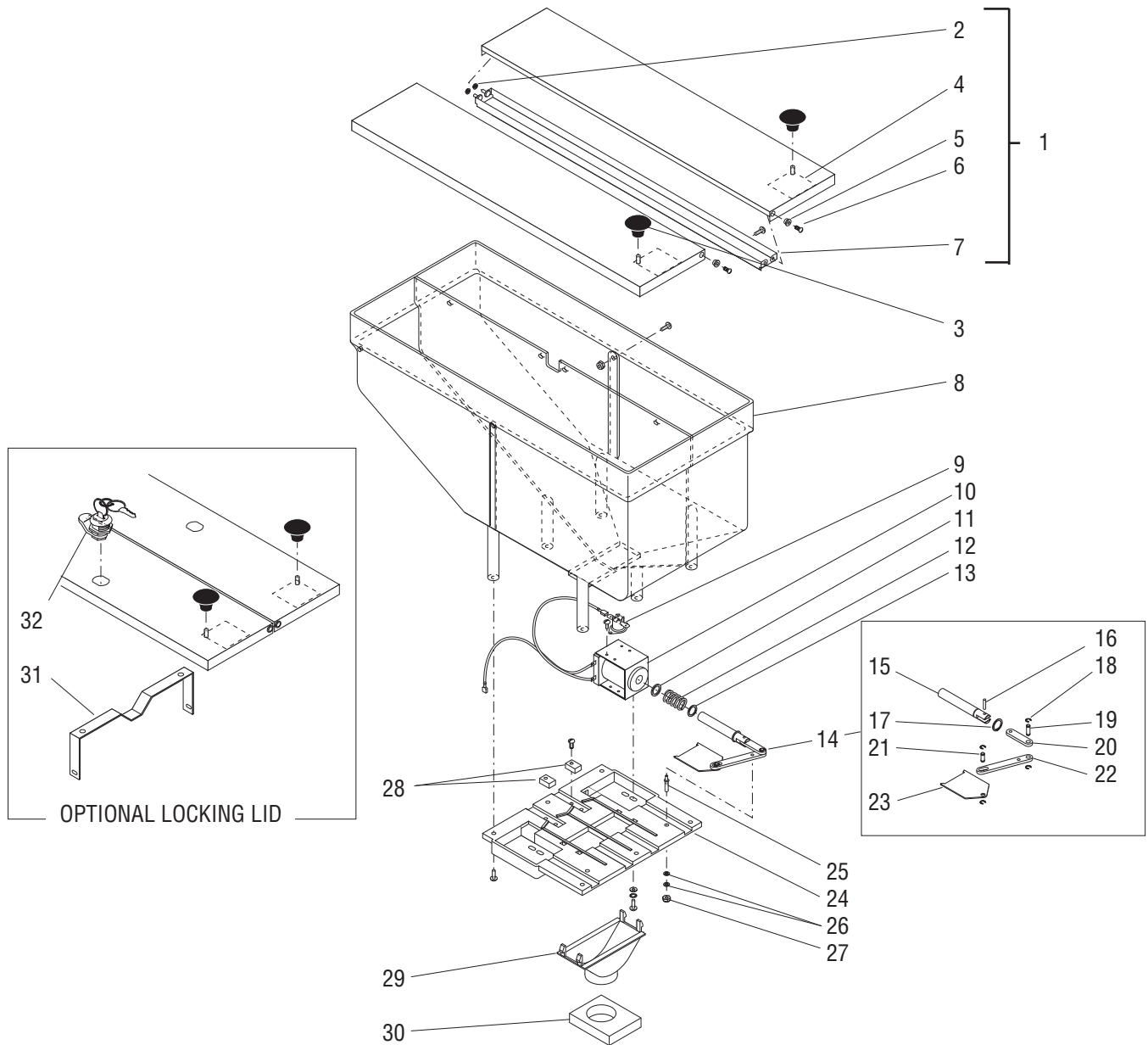

HOPPER, LID & SLIDE PLATE ASSEMBLY

ITEM	PART NO.	QTY.	DESCRIPTION
1	29431.0000	1	Lid Assy, Left SST (Includes items 2,4,5 & 6)
	29431.0001	1	Lid Assy, Right SST (Includes items 2,4,5 & 6)
	24399.0004	1	Lid Assy, Left & Right BLK (Includes items 2-7)
	24399.0002	1	Lid Assy, Locking (Includes items 2-7)
	02328.0000	4	Screw, Pan Head #6-32 x .38"
2	26033.0001	2	Bearing, Snap-in (Early Models)
	21438.0001	2	Washer, Shoulder .144" I.D. (Late Models)
3	00725.0000	2	Knob
4	05876.0000	2	Decal, Caution
5	21438.0001	2	Washer, Shoulder .144" I.D.
6	02328.0000	2	Screw, Pan Head SST #6-32 x .375"
	01382.0007	2	Screw, Truss Head BLK #6-32 x .375"
7	29358.0000	1	Channel, Hopper Lid Mounting SST
	29358.0001	1	Channel, Hopper Lid Mounting BLK
8	05960.0000	1	Hopper Assy W/Inserts
	02367.0000	2	Screw, Truss Head #6-32 x .62"
	01380.0000	2	Screw, Truss Head #6-32 x .50"
	00991.0002	4	Nut, Hex #6-2
9	23917.0000	2	Limit Thermostat
	01311.0000	8	Screw, Truss Head #8-32 x .25"
10	05939.0003	2	Solenoid Assy 120V
	05939.0004	2	Solenoid Assy 230V
	05939.0007	2	Solenoid Assy 100V
	02308.0000	8	Screw, Pan Head #8-32 x .38"
	01501.0000	8	Washer, Flat
11	23923.0000	2	Washer, Fiber .063" Thick
12	23918.0000	2	Spring
13	23922.0000	2	Washer, Retaining .035" Thick
14	05969.0000	2	Slide Plate/Linkage Assy (Includes items 15 thru 23)
15	-----	2	Plunger (Not available seperately order item 14)
16	02858.0000	2	Pin, Spring .125" x .50"
17	23919.0000	2	Snap Ring
18	01403.0000	8	E-Ring
19	05914.0002	2	Pin, Linkage .19" x .39"
20	05911.0001	2	Link, Slide Plate (Short)
21	05914.0001	2	Pin, Linkage .19" x .30"
22	05910.0000	2	Link, Slide Plate (Long)
23	05912.1000	2	Slide Plate

(Continued)

* Indicates the part number listed is for reference only. See DESCRIPTION for possible service replacement.

(Continued)

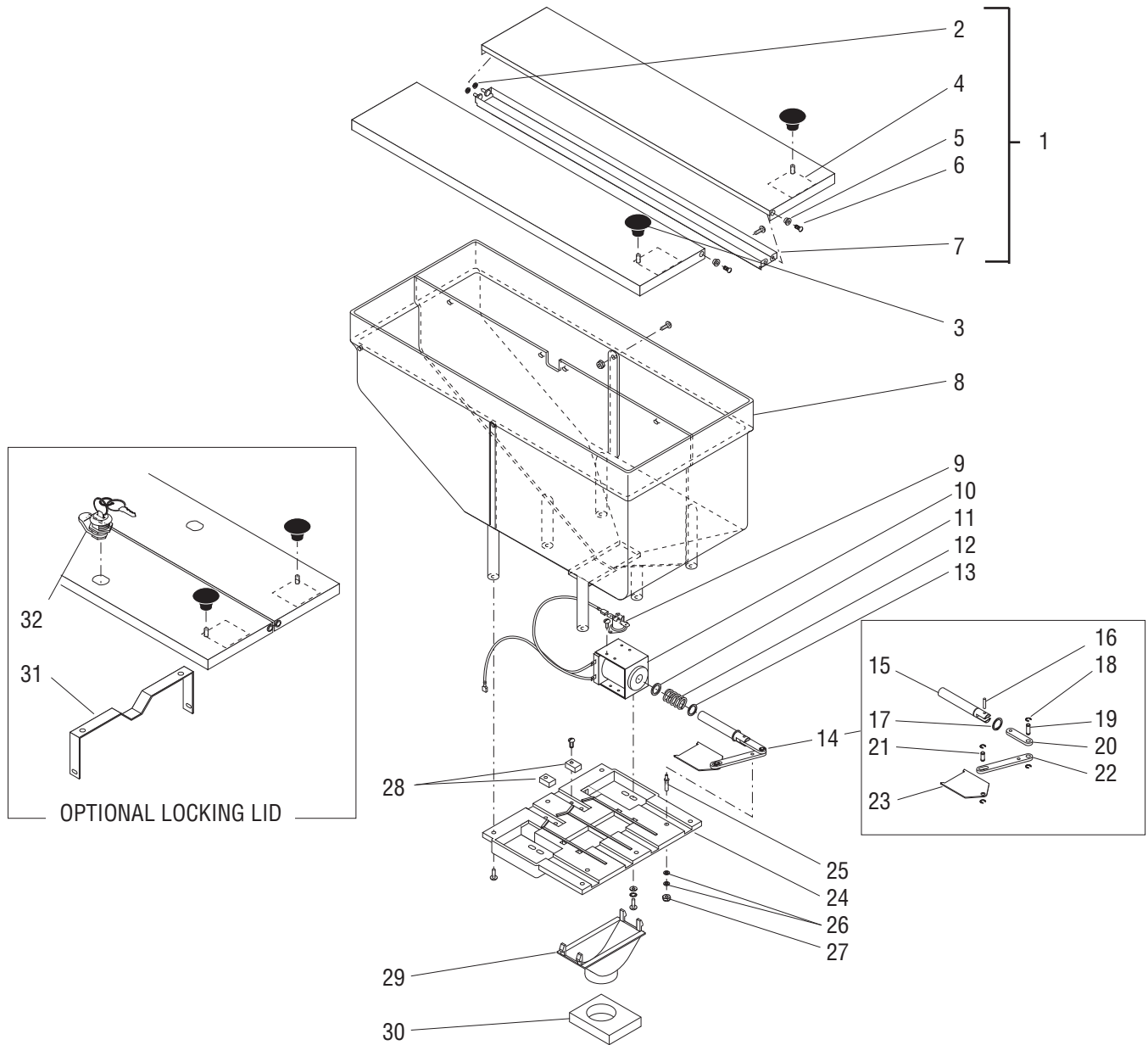

HOPPER, LID & SLIDE PLATE ASSEMBLY

ITEM	PART NO.	QTY.	DESCRIPTION
24	05959.0001	1	Mounting Panel Assy, Slide Plate (Includes items 25, 26 & 27)
	01317.0000	6	Screw, Truss Head #8-32 x .50"
25	23920.0000	2	Pin, Pivot
26	01547.0000	4	Spacer .062" Thick
27	00991.0000	2	Nut, Elastic Lock #8-32
28	23921.0000	2	Block, Stop
	02336.0000	2	Screw, Truss Head #4-20 x .38" } Early Models
29	05916.0000	1	Collector
30	21457.0001	1	Gasket, Burr Housing/Collector
31	05970.0001*	1	Bracket, Lid Locking
32	11628.0000	2	Lid Lock Assy. (Inckudes Keys)(New Keys should be made locally)
33	38549.0000	-	Gauge, To set depth of slide gate during Solenoid replacement (Not Illustrated)

* Indicates the part number listed is for reference only. See DESCRIPTION for possible service replacement.

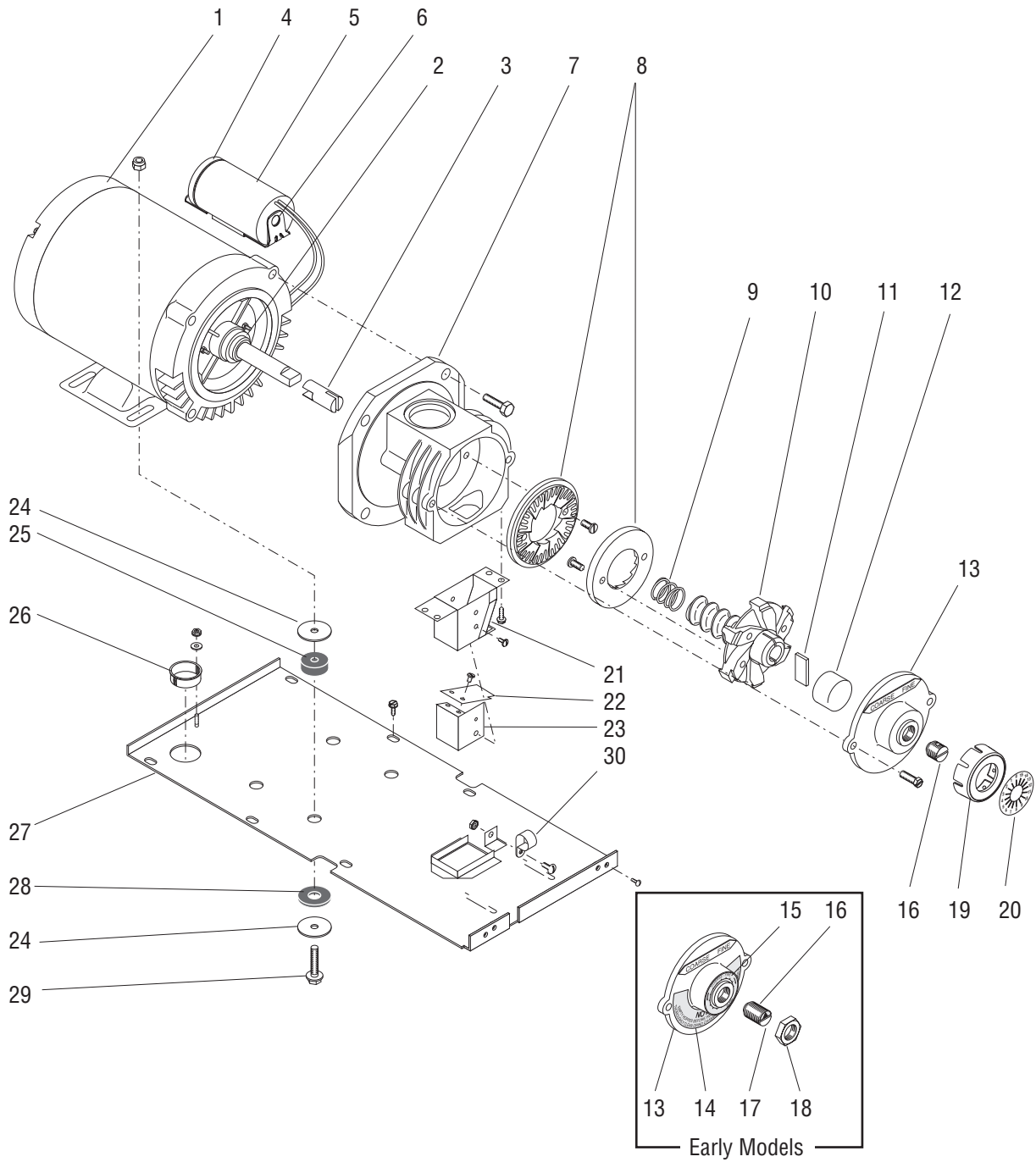

MOTOR, BURR HOUSING AND MOUNTING PLATE

ITEM	PART NO.	QTY.	DESCRIPTION
1	11029.1005	1	Motor Assy 120V (Includes items 2-6)
	11029.1006	1	Motor Assy 100V & 230V (Includes items 2-6)
2	05870.0000	1	Bushing, Bronze
3	11191.0001	1	Shaft Extension
4	35249.0000	1	Capacitor
5	35906.0000	1	Cap
6	35233.0000	1	Bracket
	37204.0000	2	Screw, Flat Head 10-32 x .375"
7	11180.0000	1	Burr Housing
	02313.0000	4	Screw, Hex Head .38"-16 x 1.0"
8	05861.1002	1	Burr Set (Includes 2 Burrs and Screws below)
	02314.0000	4	Screw, Pan Head .25"-20 x .50"
9	11192.0000	1	Spring
10	11185.0001	1	Burr Auger Rotor/Spring Assy (Includes item 9)
11	05852.0001	1	Shear Plate
12	00622.0000	1	Cup, Burr Rotor (Standard)
	00622.0001	1	Cup, Burr Rotor (Heavy Duty)
13	05867.0000	1	Cap, Burr Housing
	20631.0000	2	Screw, Slotted Hex Head .25"-20 x .75"
14	05868.0000	1	Decal, Housing Cover
15	05880.0000	1	Decal, Grind Indicator
16	05864.0000	1	Adjusting Screw (Early Models)
	35184.0000	1	Adjusting Screw (Late Models)
17	05796.0000	1	Decal, Adjusting Screw
18	00989.0000	1	Nut, Locking (Early Models)
19	34107.0000	1	Cap, Indicator Adjustment
20	34213.0000	1	Decal, Burr Adjustment
21	05951.0000	1	Chute
	02330.0001	4	Screw, Slotted Hex Head #10-24 x .375"
22	05995.0000	1	Dechaffer Plate
	02327.0002	2	Screw, Pan Head #4-40 x .312"
23	05954.0000	1	Dechaffer Assy (Includes item 19)
	02328.0002	1	Screw, Pan Head #6-32 x .188"
24	01539.0000	8	Washer, Flat
25	05881.0000	4	Bushing

} Also order item 17

(Continued)

* Indicates the part number listed is for reference only. See DESCRIPTION for possible service replacement.

(Continued)

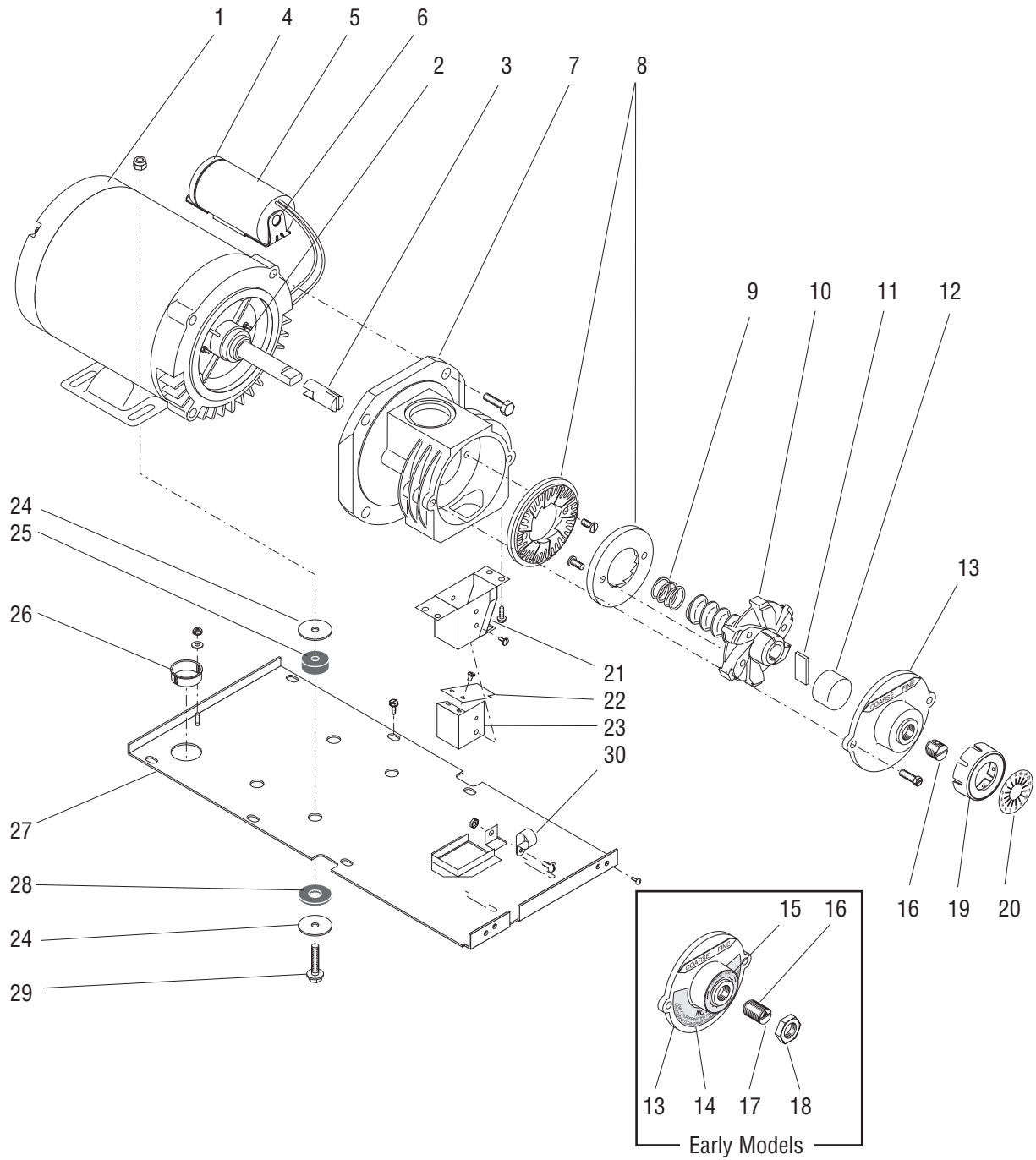

MOTOR, BURR HOUSING AND MOUNTING PLATE

ITEM	PART NO.	QTY.	DESCRIPTION
26	00718.0000	1	Bushing 1.125" Dia. Hole
27	29883.0002	1	Plate, Motor Mounting
	02311.0000	6	Screw, Slotted Hex Head #10-32 x .50"
	01347.0000	2	Screw, Truss Head #6-32 x .38"
28	05882.0000	4	Washer 1.50" Dia.
29	02312.0000	4	Screw, Hex Washer Head .312"-18 x 1.50"
	00987.0000	4	Nut, Lock .312"-18
30	05920.0000	1	Clamp, Cable .250" I.D.
	01315.0000	1	Screw, Truss Head #8-32 x .375"
	00970.0000	1	Nut, Keps #8-32

* Indicates the part number listed is for reference only. See DESCRIPTION for possible service replacement.

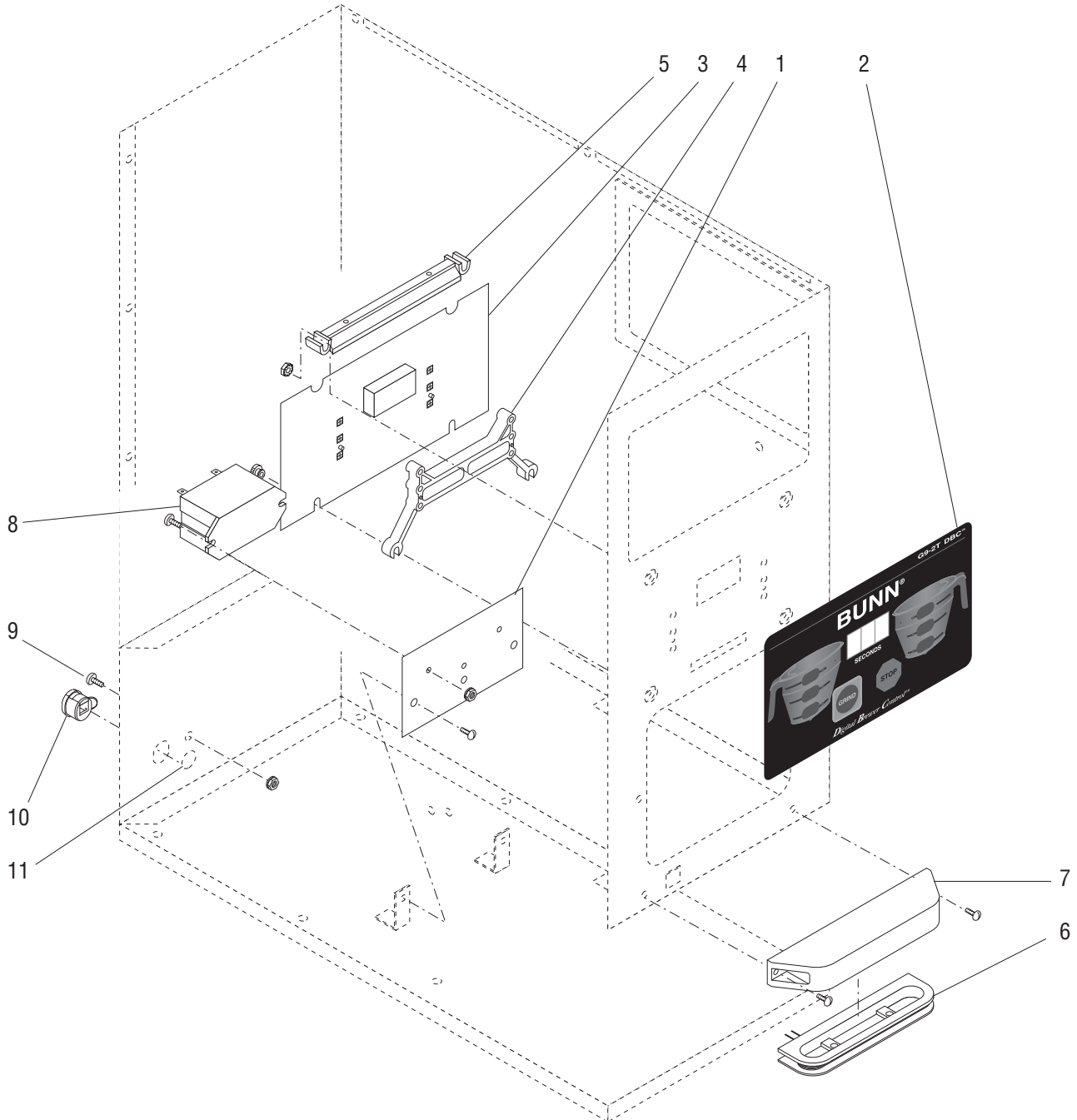

ELECTRICAL CONTROLS

ITEM	PART NO.	QTY.	DESCRIPTION
1	29870.0001	1	Bracket
	01315.0000	2	Screw, Truss Head #8-32 x .375"
	01516.0000	2	Washer, Screw Retaining #8
2	29975.0000	1	Membrane Switch 120V & 230V
	29975.0002	1	Membrane Switch 100V
	35284.0000	1	Membrane Switch 100V MB & 230V MB
3	29972.1000	1	Control Board 120V
	38724.1001	1	Control Board 230V
	29972.1005	1	Control Board 100V
	29972.1006	1	Control Board 100V MB
	38724.1002	1	Control Board 230V MB
	33902.0000	2	Knurled Nut #6-32
4	32156.0000	1	Spacer
5	29970.0001	1	Mount
	00973.0000	2	Nut, Keps #6-32
6	33302.0000	1	Sensing Coil, Grinder
7	33303.0000	1	Cover, Sensing Coil
	01347.0002	2	Screw, Truss Head Blk #6-32 x .38"
8	37711.0000	1	Relay 120V
	05893.0000	1	Relay 100V
	01347.0000	1	Screw, Truss Head #6-32 x .375"
	37711.0001	1	Relay 230V
	00973.0000	2	Nut
9	01327.0000	1	Screw, Ground Truss Head SST #10-32 x .38"
	00991.0003	1	Nut, Elastic Lock #10-32
	01375.0000	1	Screw, Ground Pan Head Slotted, Brass #10-32 x .50"
	01512.0000	1	Washer, Ext. tooth #10 Zinc Plated
	00909.0000	1	Nut, Brass #10-32
			} 100V & 120V Models
			} 230V Models
10	01686.0000	1	Bushing, Strain Relief 100V & 120V
	05746.0000	1	Bushing, Strain Relief 230V
11	00824.0002	1	Decal, Ground 230V
Note: The following items are not illustrated			
12	33635.0000	1	Wiring Harness, Main
13	29864.0000	1	Wiring Harness, Sensing Coil
14	21005.0561	2	Lead, Electrical White/Black 10.0" (Hopper Solenoid to Main Harness)
15	40699.0004	1	Cord Assy, Power 100V & 120V
	27728.0001	1	Cord Assy, Power 230V
16	00617.0000	2	Tie, Cable
17	00603.0000	2	Clamp .438" I.D.
	00971.0000	1	Nut, Keps #10-32
18	34869.0001	1	Shield, Circuit Board

* Indicates the part number listed is for reference only. See DESCRIPTION for possible service replacement.

NUMERICAL INDEX

PART NO.	PAGE NO.	PART NO.	PAGE NO.	PART NO.	PAGE NO.	PART NO.	PAGE NO.
00603.0000.....	17	05816.0000.....	5	25126.0000.....	5	39586.1000.....	7
00617.0000.....	17	05838.1000.....	5	26033.0001.....	9	40699.0004.....	17
00622.0000.....	13	05838.1001.....	5	27728.0001.....	17		
00622.0001.....	13	05852.0001.....	13	29358.0000.....	9		
00718.0000.....	15	05861.1002.....	13	29358.0001.....	9		
00725.0000.....	9	05864.0000.....	13	29431.0000.....	9		
00824.0002.....	17	05867.0000.....	13	29431.0001.....	9		
00879.0000.....	7	05868.0000.....	13	29864.0000.....	17		
00909.0000.....	17	05870.0000.....	13	29870.0001.....	17		
00917.0000.....	5	05876.0000.....	5,9	29883.0002.....	15		
00970.0000.....	15	05880.0000.....	13	29970.0001.....	17		
00971.0000.....	17	05881.0000.....	13	29972.1000.....	17		
00973.0000.....	17	05882.0000.....	15	29972.1005.....	17		
00987.0000.....	15	05884.0000.....	5	29972.1006.....	17		
00989.0000.....	13	05893.0000.....	17	29975.0000.....	17		
00991.0000.....	11	05910.0000.....	9	29975.0002.....	17		
00991.0002.....	9	05911.0001.....	9	32156.0000.....	17		
00991.0003.....	17	05912.1000.....	9	32561.0000.....	7		
01311.0000.....	9	05914.0001.....	9	32562.0001.....	7		
01315.0000.....	5,15,17	05914.0002.....	9	32568.0000.....	5		
01317.0000.....	7,11	05916.0000.....	11	32568.0001.....	5		
01326.0008.....	7	05920.0000.....	15	32569.0000.....	5		
01327.0000.....	17	05921.0000.....	5	32569.0001.....	5		
01347.0000.....	15,17	05939.0003.....	9	32570.0000.....	7		
01347.0002.....	17	05939.0004.....	9	33302.0000.....	17		
01375.0000.....	17	05939.0007.....	9	33303.0000.....	17		
01380.0000.....	5,9	05940.0000.....	7	33635.0000.....	17		
01382.0002.....	5	05951.0000.....	13	33732.1000.....	5		
01382.0007.....	9	05954.0000.....	13	33732.1001.....	5		
01403.0000.....	9	05959.0001.....	11	33733.1000.....	5		
01501.0000.....	9	05960.0000.....	9	33733.1001.....	5		
01512.0000.....	17	05969.0000.....	9	33734.0000.....	5		
01516.0000.....	17	05970.0001.....	11	33735.0000.....	5		
01518.0000.....	5	05995.0000.....	13	33735.0002.....	5		
01539.0000.....	13	11029.1005.....	13	33739.0000.....	5		
01547.0000.....	11	11029.1006.....	13	33902.0000.....	17		
01686.0000.....	17	11180.0000.....	13	34107.0000.....	13		
02308.0000.....	9	11185.0001.....	13	34213.0000.....	13		
02311.0000.....	5,15	11191.0001.....	13	34869.0001.....	17		
02312.0000.....	15	11192.0000.....	13	35184.0000.....	13		
02313.0000.....	13	11628.0000.....	11	35233.0000.....	13		
02314.0000.....	13	20545.0000.....	5	35249.0000.....	13		
02322.0002.....	5	20631.0000.....	13	35284.0000.....	17		
02327.0002.....	13	21005.0561.....	17	35906.0000.....	13		
02328.0000.....	9	21438.0001.....	9	36398.0000.....	7		
02328.0002.....	13	21457.0001.....	11	37204.0000.....	13		
02330.0001.....	13	23917.0000.....	9	37711.0000.....	17		
02336.0000.....	11	23918.0000.....	9	37711.0001.....	17		
02367.0000.....	9	23919.0000.....	9	37881.0000.....	7		
02858.0000.....	9	23920.0000.....	11	37966.1000.....	5		
02999.0000.....	5	23921.0000.....	11	37966.1001.....	5		
05746.0000.....	17	23922.0000.....	9	38170.1001.....	5		
05752.0000.....	5	23923.0000.....	9	38278.1002.....	7		
05752.0001.....	5	24237.0000.....	5	38549.0000.....	11		
05796.0000.....	13	24399.0002.....	9	38724.1001.....	17		
05814.0001.....	5	24399.0004.....	9	38724.1002.....	17		