

Krea

**Espresso
Fresh brew
120V 60Hz UL NSF**

EN English



Doc. No. H 4485EN00
EDITION 1 09 - 2013

N&W GLOBAL VENDING S.p.A.

ad unico socio

Sede legale: Via Roma 24
24030 Valbrembo (BG) Italia

Telefono +39 035 606111
Fax +39 035 606463
www.nwglobalvending.com

Cap. Soc. € 41.138.297,00 i.v.
Reg. Impr. BG, Cod. Fisc. e P. IVA: 05035600963
Reg. Produttori A.E.E.: IT08020000001054

Valbrembo, 01/01/2012

**DICHIARAZIONE DI CONFORMITA'
DECLARATION OF CONFORMITY
DÉCLARATION DE CONFORMITÉ
KONFORMITÄTSERKLÄRUNG
DECLARACIÓN DE CONFORMIDAD
DECLARAÇÃO DE CONFORMIDADE
VERKLARING VAN OVEREENSTEMMING**



Italiano Si dichiara che la macchina, descritta nella targhetta di identificazione, è conforme alle disposizioni legislative delle Direttive Europee elencate a lato e successive modifiche ed integrazioni.

English The machine described in the identification plate conforms to the legislative directions of the European directives listed at side and further amendments and integrations

Français La machine décrite sur la plaquette d'identification est conforme aux dispositions légales des directives européennes énoncées ci-contre et modifications et intégrations successives

Deutsch Das auf dem Typenschild beschriebene Gerät entspricht den rechts aufgeführten gesetzlichen Europäischen Richtlinien, sowie anschließenden Änderungen und Ergänzungen

Español Se declara que la máquina, descrita en la etiqueta de identificación, cumple con las disposiciones legislativas de las Directrices Europeas listadas al margen y de sus sucesivas modificaciones e integraciones

Português Declara-se que a máquina, descrita na placa de identificação está conforme as disposições legislativas das Diretrizes Europeias elencadas aqui ao lado e sucessivas modificações e integrações

Nederlands De machine beschreven op het identificatieplaatje is conform de wetsbepalingen van de Europese Richtlijnen die hiernaast vermeld worden en latere amendementen en aanvullingen

Italiano Le norme armonizzate o le specifiche tecniche (designazioni) che sono state applicate in accordo con le regole della buona arte in materia di sicurezza in vigore nella UE sono:

English The harmonised standards or technical specifications (designations) which comply with good engineering practice in safety matters in force within the EU have been applied are:

Français Les normes harmonisées ou les spécifications techniques (désignations) qui ont été appliquées conformément aux règles de la bonne pratique en matière de sécurité en vigueur dans l'UE sont :

Deutsch Die harmonisierten Standards oder technischen Spezifikationen (Bestimmungen), die den Regeln der Kunst hinsichtlich den in der EU geltenden Sicherheitsnormen entsprechen, sind:

Español Las normas armonizadas o las especificaciones técnicas (designaciones) que han sido aplicadas de acuerdo con las reglas de la buena práctica en materia de seguridad vigentes en la UE son:

Português As normas harmonizadas ou as especificações técnicas (designações) que foram aplicadas de acordo com boas regras de engenharia em matéria de segurança em vigor na UE são:

Nederlands De geharmoniseerde normen of technische specificaties (aanwijzingen) die toegepast werden volgens de in de EU van kracht zijnde eisen van goed vakmanschap inzake veiligheid zijn de volgende:

**Targhetta di identificazione
Identification label**

Direttive europee European directives	Sostituita da Repealed by
2006/42/EC	
73/23/EC + 93/68/CE	2006/95/CE
89/336/EC + 92/31/CE + 93/68/CE	2004/108/EC
90/128/EC	2002/72/CE
80/590/EEC and 89/109/EEC	EC 1935/2004
EC 10/2011	
2002/96/EC	

Norme armonizzate / Specifiche tecniche	Harmonised standards Technical specifications
EN 60335-1:2002 + A1:2004 + A11:2004 + A12:2006 + A2:2006+ A13:2008	
EN 60335-2-75:2004 + A1:2005 + A11:2006 + A2:2008 + A12:2010	
EN 62233:2008	
EN 55014-1: 2006 + A1: 2009	
EN 55014-2: 1997 + A1: 2001 + A2: 2008	
EN 61000-3-2: 2006 + A1: 2009 + A2: 2009	
EN 61000-3-3: 2008	
EN 61000-4-2: 2009	
EN 61000-4-3: 2006 + A1: 2008	
EN 61000-4-4: 2004	
EN 61000-4-5: 2006	
EN 61000-4-6: 2009	
EN 61000-4-11: 2004	

Il fascicolo tecnico è costituito presso:

The technical file is compiled at:

N&W GLOBAL VENDING S.p.A.

ANDREA ZOCCHI

C.E.O

Declaration of conformity

The declaration of conformity with the European Directives and Standards provided for by the laws in force is supplied by the first page of this manual, which is an integral part of the machine.

 It is declared that the machine described by the identification plate is in compliance with the provisions of the European Directives, its subsequent amendments and integrations as well as with the harmonised standards or technical specifications (designations) applied in compliance with the safety rules of good practice enforced in the EU and listed on the same page.

Warnings

FOR INSTALLATION

The installation and any subsequent maintenance operation shall be carried out by the personnel skilled and trained on the utilisation of the machine according to the rules in force.

The machine is sold without any payment system. As a consequence, only the installer will be liable for any damage that may be caused to the machine or to things and persons by an incorrect installation of the payment system.

The intactness of the machine and its compliance with the standards of relevant installations must be checked by skilled personnel at least once a year.

Package materials must be disposed of in observance of the environment.

Important!

The machine is equipped with an automatic washing system for the mixers with the relative water circuit and the brewing unit.

If the machine is not used for some time (weekends, etc.) even for pauses longer than two days, it is recommended to enable the automatic washing functions (e.g. before starting to use the VM).

FOR USE

The machine can be used by children and by people having reduced physical, sensorial or mental skills under the supervision of people responsible for their safety or specifically trained on the use of the machine. Children shall be prevented from playing with the machine by the people in charge of their supervision.

FOR THE ENVIRONMENT

Some tricks will help you to protect the environment:

- use biodegradable products to clean the machine;
- properly dispose of all the packages of the products used to fill and clean the machine;
- power off the machine during inactivity for energy saving.

FOR DISMANTLING AND DISPOSAL



When dismantling the machine, it is recommended to destroy the machine rating plate.

The symbol shows that the machine can not be disposed of as common waste, but it must be

disposed of as it is established by the 2002/96/CE (Waste Electrical and Electronics Equipments - WEEE) European Directive and by the national laws arising out of it in order to prevent any negative consequence for environment and human health.

The differentiated collection of the machine at the end of its life is organised and managed by the manufacturer.

For the correct disposal of the machine contact the sales point where you have purchased the machine or our after-sales service.

The unlawful disposal of the machine implies the application of the administrative sanctions provided for by the rules in force.

Attention!

If the machine is equipped with a cooling system, the cooling unit contains HFC-R134a fluoridised greenhouse effect gas ruled by the Kyoto protocol, the total heating potential of which is equal to 1300.

Symbology

The following symbols may be present inside the machines, according to models:



Attention: dangerous voltage
Power off before removing the cover



Attention
Danger of crushing your hands



Attention
Hot surface



THE INTERNATIONAL CERTIFICATION NETWORK

CERTIFICATE

IQNet and its partner
CISQ/IMQ-CSQ
hereby certify that the organization

N&W GLOBAL VENDING SPA
VIA ROMA 24 - 24030 VALBREMBO (BG)
VIA DEL CHIOSO 13 - 24030 MOZZO (BG)
VIA DELEDDA 16 - 24030 MAPELLO (BG)
VIA SALVO D'ACQUISTO 7/9 - 24050 GRASSOBBIO (BG)

for the following field of activities
Design, manufacturing and sale of electronical and electromechanical vending machines

Refer to quality manual for details of applications to ISO 9001:2008 requirements

has implemented and maintains a
Quality Management System
which fulfills the requirements of the following standard

ISO 9001:2008

Issued on: 2012 - 05 - 08

Expiry date: 2015 - 05 - 31

Registration Number: IT - 12979



Michael Drechsel
President of IQNET



Gianrenzo Prati
President of CISQ

IQNet Partners:*

AENOR Spain AFNOR Certification France AIB-Vinçotte International Belgium ANCE Mexico APCER Portugal CCC Cyprus
CISQ Italy CQC China CQM China CQS Czech Republic Cro Cert Croatia DQS Holding GmbH Germany DS Denmark
ELOT Greece FCAV Brazil FONDONORMA Venezuela ICONTEC Colombia IMNC Mexico INNORPI Tunisia
Inspecta Certification Finland IRAM Argentina JQA Japan KFQ Korea MSZT Hungary Nemko AS Norway NSAI Ireland
PCBC Poland Quality Austria RR Russia SII Israel SIQ Slovenia SIRIM QAS International Malaysia SQS Switzerland
SRAC Romania TEST St Petersburg Russia TSE Turkey YUQS Serbia

IQNet is represented in the USA by: AFNOR Certification, CISQ, DQS Holding GmbH and NSAI Inc.

* The list of IQNet partners is valid at the time of issue of this certificate. Updated information is available under www.iqnet-certification.com



THE INTERNATIONAL CERTIFICATION NETWORK

CERTIFICATE

IQNet and its partner
CISQ/IMQ-CSQ
hereby certify that the organization

N&W GLOBAL VENDING SPA

VIA ROMA 24 - 24030 VALBREMBO (BG)

VIA DEL CHIOSO 13 - 24030 MOZZO (BG)

VIA GRAZIA DELEDDA 16 - 24030 MAPELLO (BG)

for the following field of activities

*Design, manufacturing by punching, bending, welding of coils and assembling operations,
and sales of electrical and electromechanical vending machines*

has implemented and maintains a
Environmental Management System
which fulfills the requirements of the following standard

ISO 14001:2004

Issued on: 2013 - 05 - 28

Expiry date: 2016 - 05 - 14

Registration Number: IT - 8753



Michael Drechsel

President of IQNET



Ing. Claudio Provetti

President of CISQ

IQNet Partners*:

AENOR Spain AFNOR Certification France AIB-Vinçotte International Belgium ANCE-SIGE Mexico APCER Portugal CCC Cyprus
CISQ Italy CQC China CQM China CQS Czech Republic Cro Cert Croatia DQS Holding GmbH Germany DS Denmark
FCAV Brazil FONDONORMA Venezuela ICONTEC Colombia IMNC Mexico INNORPI Tunisia
Inspecta Certification Finland IRAM Argentina JQA Japan KFQ Korea MIRTEC Greece MSZT Hungary Nemko AS Norway
NSAI Ireland PCBC Poland Quality Austria Austria RR Russia SII Israel SIQ Slovenia SIRIM QAS International Malaysia
SQS Switzerland SRAC Romania TEST St Petersburg Russia TSE Turkey YUQS Serbia

IQNet is represented in the USA by: AFNOR Certification, CISQ, DQS Holding GmbH and NSAI Inc.

* The list of IQNet partners is valid at the time of issue of this certificate. Updated information is available under www.iqnet-certification.com

English

TABLE OF CONTENTS

	PAGE		PAGE
DECLARATION OF CONFORMITY			
WARNING			
FOREWORD	2	LOADER MENU	24
IDENTIFICATION OF THE MACHINE AND FEATURES	2	STATISTICS	24
IN CASE OF FAILURE	2	INDIVIDUAL PRICE	25
TRANSPORT AND STORAGE	2	MANAGEMENT OF THE COIN BOX TUBES	25
POSITIONING OF THE VENDING MACHINE	3	BOILER TEMPERATURE	25
		TEST	25
TECHNICAL CHARACTERISTICS	3	EVA DTS	25
ACCESSORIES	5	ENGINEER MENU	26
VARIABLE COMBINATION LOCKS	6	PAYMENT SYSTEMS	26
CLEANING AND LOADING	7	PRICES	30
DOOR SWITCH	7	DOSES	30
CLEANING AND STERILISATION	7	DA CONFIGURATION	33
USE OF HOT BEVERAGE DISPENSERS IN OPEN CONTAINERS	7	TEST	38
		STATISTICS	39
CONTROLS AND INFORMATION	8	COMMUNICATION	42
PRODUCT LOADING	8	FAULTS	42
MACHINE SANITIZATION	9	MAINTENANCE	45
STERILISATION OF THE MIXERS AND OF THE FOOD PRODUCTS		GENERALITIES	45
CIRCUITS	9	DOOR SWITCH	45
START-UP	12	ESPRESSO UNIT MAINTENANCE	46
SERVICE SUSPENSION	13	PERIODICAL OPERATIONS	48
INSTALLATION	14	STERILISATION	48
DOOR SWITCH	14	PRODUCTS CONTAINERS	49
UNPACKING THE VENDING MACHINE	14	BOILER MAINTENANCE	50
POSITIONING OF THE VENDING MACHINE	14	BOARDS FUNCTION	51
INSERTING THE PLATES	15	CONFIGURATION OF ELECTRONIC BOARDS	51
WATER SUPPLY	15	ACTIVATION BOARD	52
ELECTRICAL CONNECTION	16	CPU BOARD	53
FIRST START-UP	17	POWER SUPPLY BOARD	54
FIRST STERILISATION MIXERS AND FOOD PRODUCT CIRCUITS	17	BOILER CONTROL BOARD	54
OPERATION	18	EXPANSION BOARD FOR PAYMENT SYSTEMS	54
GRINDER-DOSER	19	APPENDIX	55
INSTANT DRINKS DISPENSING	21		
PROGRAMMING	22		
OPERATION IN NORMAL USER STATUS	22		
NAVIGATION	23		
ENTERING THE PROGRAMMING MODE	23		

Foreword

The technical documentation forms an integral part of the equipment and must therefore accompany any movement or transfer of ownership in order to allow further consultations by the operators.

Before installing and using the equipment you need to scrupulously read and understand the contents of the documentation, as it provides important information related to installation safety, to the utilisation standards and to the maintenance operations.

The manual is divided into three chapters.

The **first chapter** describes the loading and ordinary cleaning operations to be performed in the areas of the machine which can be accessed through just the use of the door opening key, without the need of using other tools.

The **second chapter** contains the instructions related to a correct installation and the information required to make the best use of the machine.

The **third chapter** describes the maintenance operations which require the use of tools for accessing potentially dangerous areas.

The operations described in the second and third chapter shall be carried out only by personnel with specific knowledge of the operation of the machine both from the point of view of electrical safety and of hygiene.

IDENTIFICATION OF THE MACHINE AND FEATURES

Each machine is identified by means of a specific serial number which can be read from the plate placed inside the machine on the right side.

The plate is the only machine identification recognised by the manufacturer and sets out all the data which enables the manufacturer to provide, promptly and safely, technical information of any kind and facilitate the management of spare parts.

IN CASE OF FAILURE

In most cases, technical problems can be solved by means of small interventions; we therefore suggest to read this manual carefully before contacting the manufacturer. In case of anomalies or malfunctioning which cannot be solved, please contact:

N&W GLOBAL VENDING S. p. A.
Via Roma 24
24030 Valbrembo
Italy - Tel. +39 035606111

TRANSPORT AND STORAGE

In order to avoid causing damage to the machine, the loading and unloading manoeuvres must be performed with particular care.

It is possible to lift the machine with a motorised or manual forklift, by positioning the fork underneath the machine and on the side which is clearly indicated by the sign on the cardboard packaging.

Instead, the following should be avoided:

- Overturning the vending machine;
- Dragging the vending machine with ropes or similar;
- Lifting the vending machine with lateral grips;
- Lifting the vending machine with straps or ropes
- Shaking the vending machine and/or the packaging.

The storage environment needs to be dry and of a temperature between 32 and 104 °F.

If the original packaging is used, it is possible, if necessary, to overlay 2 machines

It is important to keep the machine in the vertical position indicated by the arrows on the packaging.

Fig. 1

- 1- Product code
- 2- Type
- 3- Model
- 4- Work voltage
- 5- Power absorbed
- 6- Boiler details
- 7- Serial No.
- 8- Frequency
- 9- Current
- 10- Water mains characteristics

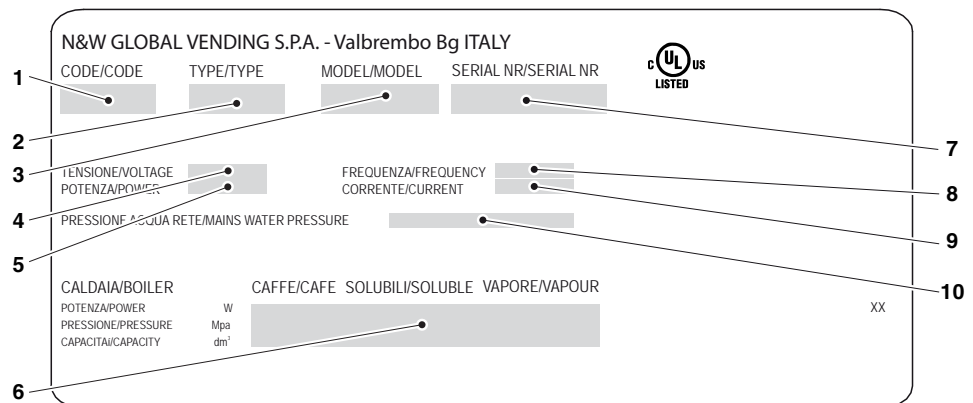

POSITIONING OF THE VENDING MACHINE

The machine is not suitable for outside installations, it needs to be installed inside dry premises, with temperature between 35.6° F and 89.6° F and it cannot be installed in environments in which jets of water are used for cleaning (i.e.: large kitchens, etc.).

The machine shall be positioned next to a wall and in such a way that the back of it is at a minimum distance of 2 cm from the wall in order to allow regular ventilation. The machine shall not be covered with cloths or similar. The machine shall be positioned so that the maximum inclination does not exceed 2°.

If needed, level it out using the appropriate adjustable feet provided with the machine.

The appliance satisfy the requirements NSF only when are used 100 mm's feet

Important

In the event of unscheduled maintenance interventions and/or repairs, the vending machine can be accessed from the back.

The possibility should therefore be envisaged of rotating the machine so that the back panel can be removed.

Positioning over cabinet

The machine can be positioned over a table or another suitable support (suggested height 32 inches). Where possible, it is advisable to use the special cabinet which can house the waste container, the water supply tank and the descaler if the water is very hard.

TECHNICAL CHARACTERISTICS

Height	inches	25.59
Height with coffee container	inches	33.46
Dimensions with open top	inches	43.31
Width	inches	16.25
Depth	inches	22.25
Dimensions with open door	inches	33.75
Weight without packaging	Lbs.	90
Supply voltage	V~	120
Power supply frequency	Hz	60
Installed power	W	1300

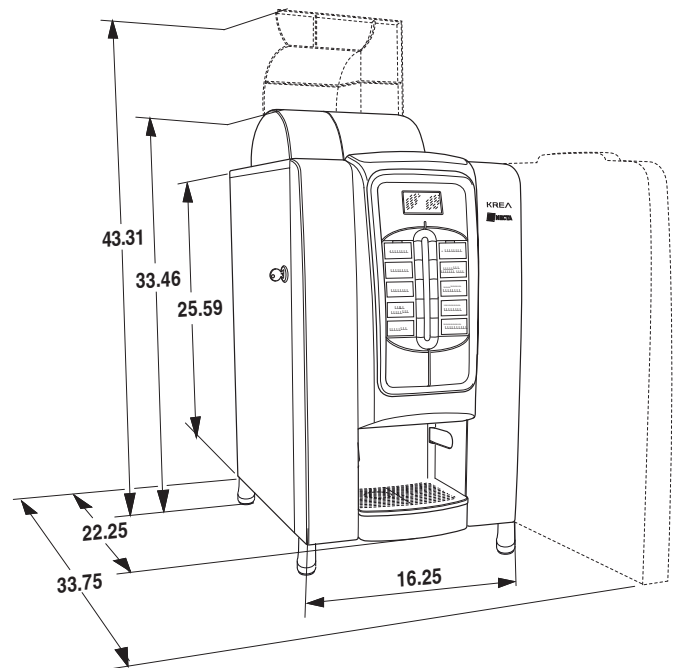

Fig. 2

BOILER

20.29 oz capacity with 1100 W heating element.

NOISE LEVEL

The weighted continuous equivalent sound pressure level is less than 70 dB.

PAYMENT SYSTEM

The machine is supplied with electrical arrangement for systems with protocol Executive, BDV, MDB and for monitoring 24 Vdc validators.

Apart from the coin box housing, there is space for the optional installation of the most common payment systems.

SALES PRICES

A different price can be programmed for each selection; The standard calibration foresees the same sales price for all selections.

WATER SUPPLY

Water supply from mains with water pressure between 7.3 psig e 123.3 psig (5 and 8.5 Bar).

The machine's software is arranged for controlling the water supply from an internal tank (optional kit which can be placed in the service cabinet).

POSSIBLE SETTINGS

Espresso	Grain size Volumetric coffee dose Volumetric water
Fresh brew	Fresh brew timed dose Volumetric water Infusion time Drying time
Instant	Product timed dose Volumetric water
Temperature	Adjustable from software

ENABLE SIGNALS

- Presence of water
- Presence of coffee
- Infuser unit position
- Liquid waste container
- The operating temperature is reached

SAFETIES

- door switch
- boiler safety thermostat with manual reset
- air-break float jamming
- shutoff solenoid
- full liquid waste container float
- boiler probes interruption/short circuit control
- time protection of:
 - Pump
 - Infuser unit gear motor
 - Coffee dispensing
 - Grinder
- thermal protection of:
 - Ingredient motors
 - Infuser unit gear motor
 - Coffee release electromagnet
 - Pump
 - Mixer motors
 - Grinder motor
- protection with fuse

CONTAINERS CAPACITY

The machine can be fitted with different combinations of containers of a different type for dispensing different types of products.

The container:

- for coffee beans has a capacity of approx. 2.25 lbs.
- for the fresh brew has a capacity of approx. 2.2 lbs.

For the instant products, depending on the models, the machine can be fitted with containers with a capacity of 33 or 67 oz

The indicative product quantity is summarised in the following table

Container dimension	33 oz	67 oz
Instant decaf	0.66 lbs	1.21 lbs
Chocolate	1.87 lbs	3.30 lbs
Milk	0.81 lbs	3.30 lbs
French Vanilla	2.42 lbs	3.63 lbs

The real quantity can differ from the one indicated because of the different specific weight of the various products.

POWER CONSUMPTION

The power consumption of the machine depends on many factors, including the temperature and ventilation of the environment where the machine is located, the temperature of the inlet water, the boiler temperature, etc.

A measurement at a room temperature of 71.6 °F was carried out and the following power consumption was detected:

Reaching the temperature Wh /

24h stand by: Wh /

The power consumption calculated on the above-mentioned average data shall be deemed as purely indicative.

ACCESSORIES

The machine can be fitted with accessories in order to vary its performances.

The installation kits are supplied with installation and test instructions, which shall be scrupulously followed in order to maintain the safety of the machine.

Important

Using kits that have not been approved by the manufacturer does not guarantee the compliance with the safety standards, especially for what concerns live-parts. The manufacturer declines any responsibility for the use of non-approved components.

The installation and the subsequent test operations shall be performed by qualified personnel, with specific knowledge of the operation of the machine both from the point of view of electrical safety and of hygiene.

VARIABLE COMBINATION LOCKS

Some models are supplied with variable combination locks.

The lock has a silver-coloured key with the standard combination to be used for normal opening and closing operations.

It is possible to customise the locks using a kit, available as an accessory, which allows the lock combination to be changed.

The kit is composed of a change key (black) for changing the standard combination and of change keys (gold) and use keys (silver) for changing and using the new combinations.

Change and use key packs with other combinations can be supplied on request.

Furthermore, other use key (silver) packs can be requested specifying the combination printed on the keys.

Usually the use key (silver) is the only one used, whereas the combination change keys (gold) may be kept as spare keys.

Avoid using the change keys for normal opening as this could damage the lock.

To change the combination:

- Open the door of the device to avoid forcing rotation;
- Lightly lubricate using a spray inside the lock;
- Insert the current change key (black) and turn it to the change position (reference notch at 120°);
- Extract the current change key and insert the change key (gold) with the new combination;
- Turn to the closing position (0°) and extract the change key.

The lock has now assumed the new combination.

The keys of the old combination can no longer be used for the new combination.

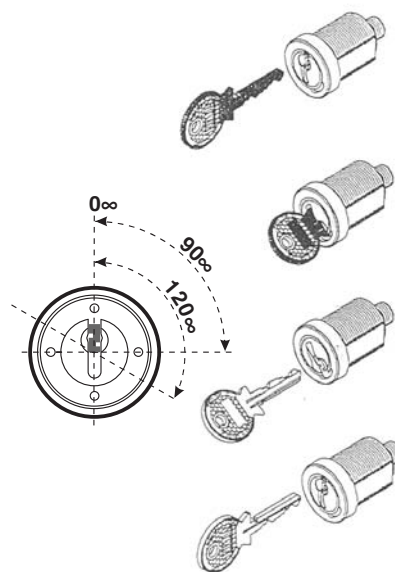

Fig. 3

Chapter 1 Cleaning and loading

The machine is not suitable for outside installations, it needs to be installed inside dry premises, with temperature between 32 and 104° F and it cannot be installed in environments in which jets of water are used for cleaning (i.e.: large kitchens, etc.).

DOOR SWITCH

When the door is opened, a switch removes the voltage from the electrical system of the machine to allow the operations, described below, of loading and ordinary cleaning, to be carried out in full safety.

All the operations which require voltage with the door open shall be EXCLUSIVELY performed by qualified personnel who has been informed of the specific risks deriving from such a situation.

CLEANING AND STERILISATION

In accordance with current health and safety regulations, the operator of a vending machine is responsible for the hygiene of the materials which are in contact with food products; the operator shall therefore carry out maintenance interventions on the machine so as to prevent the formation of bacteria.

When the machine is installed, the hydraulic circuits and the parts in contact with the food products need to be sterilised in order to eliminate any bacteria which could have formed during storage.

It is recommended that sterilising products also be used when cleaning the surfaces which are not directly in contact with the food products. Some parts of the machine can be damaged by aggressive detergents.

The manufacturer shall not be held responsible for any damage caused by the non-observance of the above or by the use of aggressive or toxic chemical products.

Always switch off the machine before starting maintenance operations which require the disassembling of components.

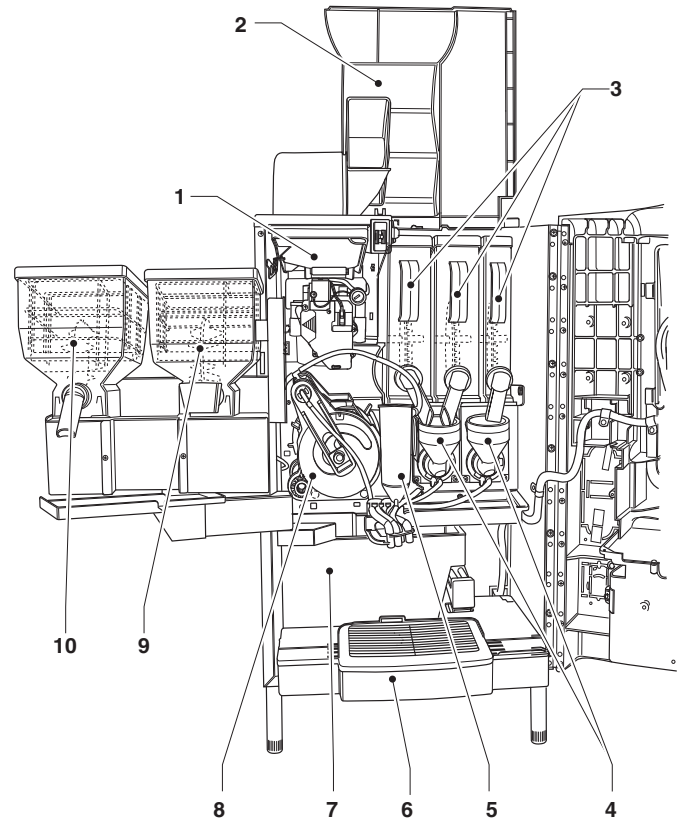

Fig. 4

- 1- Container for coffee beans
- 2- Upper panel
- 3- Instant powder containers
- 4- Mixer
- 5- Expansion nozzle
- 6- Liquid residue container
- 7- Solid residue container
- 8- Infuser unit
- 9- Fresh brew container
- 10- Instant powder container

USE OF HOT BEVERAGE DISPENSERS IN OPEN CONTAINERS

(e.g. plastic cups, ceramic cups, pitchers)

The vending machines in open containers shall be used exclusively for the sale and distribution of drinks which are produced by:

- Infusion of products such as coffee and tea;
 - Reconstitution of instant drink or freeze dried products;
- These products shall be declared by the producer as "suitable for vending machines" in open containers.

The products dispensed need to be consumed immediately. The products can in no case be kept and/or packaged for subsequent consumption.

Any other use is considered improper and therefore potentially dangerous.

CONTROLS AND INFORMATION

The controls and the information to the user are on the external side of the door.

The plates with the menu and the instructions are supplied together with the machine and they shall be inserted when the machine is installed.

The Programming button, which provides access to the machine's functions, and the service buttons are located inside the machine on the buttons board.

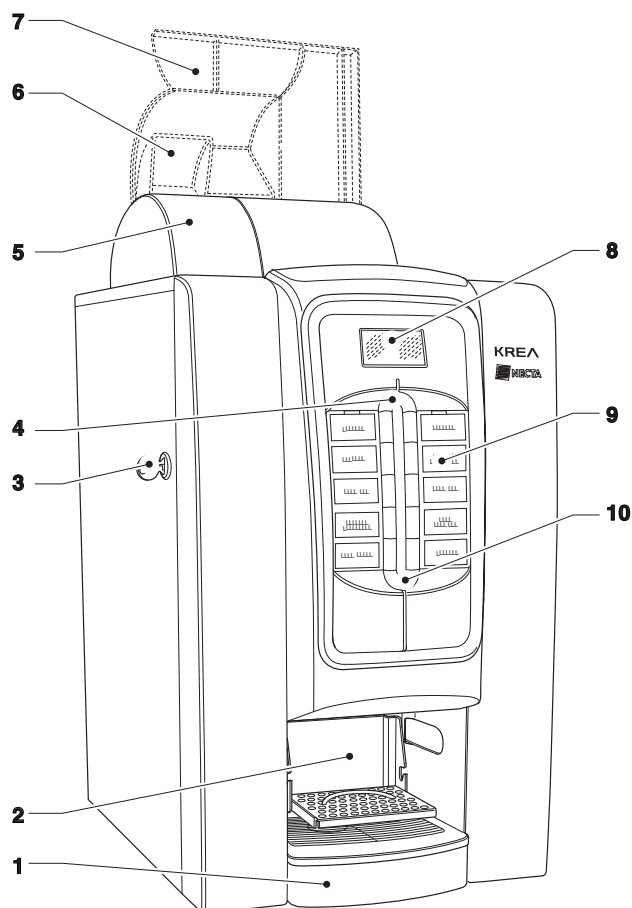

Fig. 5

- 1- Liquid residue container
- 2- Dispensing unit
- 3- Door lock
- 4- Upper light guide
- 5- Container for coffee beans
- 6- Coffee container cover
- 7- Openable upper panel
- 8- Display
- 9- Selections menu
- 10- Lower light guide

PRODUCT LOADING

Before loading the products, please verify they are in strict accordance with the manufacturer instructions regarding storage, storage temperature and expiry date.

Load the products following the guidelines below.

Products may also be loaded with the containers partially full

COFFEE BEANS (ESPRESSO)

Lift the machine upper panel.

Fill it with coffee beans (2.65 lbs max), checking that the damper of the container is completely open.

FRESH BREW

Lift the machine upper panel.

Fill it with the fresh brew (3 lbs max) being careful not to compress it.

Make sure the product does not contain any lumps

INSTANT PRODUCTS

Each container has an adhesive label which specifies the type of product.

After lifting the corresponding cover, introduce the products to be dispensed into the containers being careful not to compress them.

Make sure that the products do not contain lumps.

MACHINE SANITIZATION

This manual shows the potential weak points and includes information about controlling the possible growth of bacteria.

Under the current health and safety regulations, the operator of the machine must apply the self-control procedures, identified in accordance with Directive HACCP (Hazard Analysis Critical Control Point) and national legislation.

With each product load or more frequently, depending on the use of the machine and the quality of incoming water and products used, it is necessary to ensure the sanitation of the machine, to ensure the hygiene of the delivered products.

The sanitization must be performed using sanitizers, taking care to mechanically remove the residues and visible films using swabs and/or brushes

Important!

The machine is equipped with an automatic washing system for the mixers with relative hydraulic circuit and the infuser unit.

If the use of the machine is subject to idle periods (weekends, etc.), even for less than two days, it is good practice to enable the automatic washing functions (before beginning to use the DA for example)

COLOURS CODE

In order to facilitate the cleaning operations, the parts that need to be regularly cleaned and sterilised are identified in blue.

Use the parts in green to disassemble the parts in blue and perform the cleaning and sterilisation operations. Only some of the parts related to the espresso infuser unit do not follow this rule as they are made of a specific material.

STERILISATION OF THE MIXERS AND OF THE FOOD PRODUCTS CIRCUITS

When the machine is installed and at least on a weekly basis, or more frequently depending on the use of the machine and of the quality of the inlet water, it is necessary to carry out an accurate sterilisation of the mixers and of the instant drinks dispensing pipes in order to ensure the hygiene of the distributed products.

Jets of water are to be absolutely avoided for cleaning.

The parts that need to be cleaned are:

- Powder funnels, expansion nozzle, mixers and instant drinks dispensing pipes;
- Pipes and dispensing nozzles;
- Dispensing unit.

Proceed as follows:

- Open the cover of the mixer dispensing cell and lift the powder nozzles up to the end stop;
- Remove the powder funnels, the water conveyors, the powder deposit funnels and the mixer motor fans from the mixers;

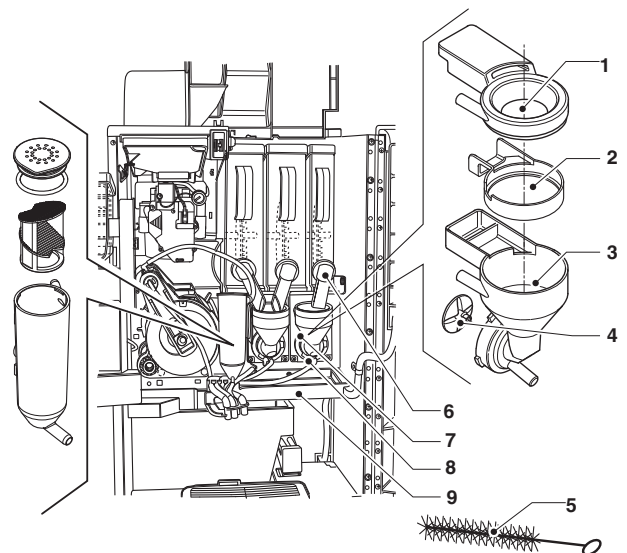

Fig. 6

- 1- Powder funnel
- 2- Splashguard ring
- 3- Water conveyor
- 4- Mixer fan
- 5- Tube cleaning brush
- 6- Powder nozzle
- 7- Mixer fixing flange
- 8- Flange fixing nut
- 9- Mixer container

- The fans can be removed by simply pulling gently to free them;

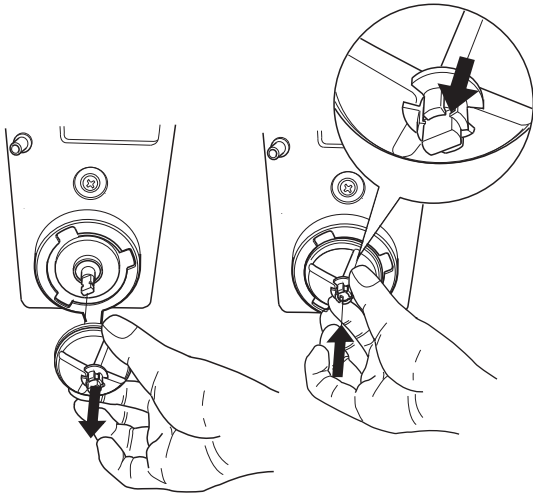

Fig. 7

- Wash all the components with sterilising products (follow the dosage indicated by the manufacturer), being careful to mechanically remove the visible residues using brushes if necessary;

The sterilisation is performed by means of sterilising products.

- Dip the parts for approx. 20 minutes in a recipient containing the previously prepared sterilising solution;
- Reinstall the conveyors and the water funnels;
- Reinstall the powder deposit drawers and the powder funnels after having carefully rinsed and dried them.

After installing the components it is however necessary:

- Wash the mixer and add a few drops of the sterilising solution into the various funnels.
- Once the sterilisation has been performed, rinse the components well in order to remove any possible residue of the solution used.

All the operations which require the machine to be under voltage shall ONLY be performed by qualified personnel who has been informed of the specific risks deriving from such a situation.

WASTE CONTAINERS

The waste containers can be easily extracted so that they can be quickly emptied and cleaned. For safety reasons, the containers can be handled only when the door is open.

LIQUID WASTE

When the appropriate float signals that the container is full, the "Full waste" message appears on the machine's display and it is necessary to empty the liquid waste container.

For removing the liquid waste container, operate as follows:

- Grab the liquid waste container by the side, lift slightly and pull towards you.
- Empty the container and wash it with a solution of neutral detergent

WASTE

The capacity of the coffee beans container, if the support cabinet is not used, is greater than the capacity of the waste container.

After a number of dispensing events corresponding to about 1.91 lbs. (corresponding to the capacity of the container), the machine will stop working and request that the solid waste container be emptied by showing the message "Empty container"

The machine will still work for dispensing instant drinks.

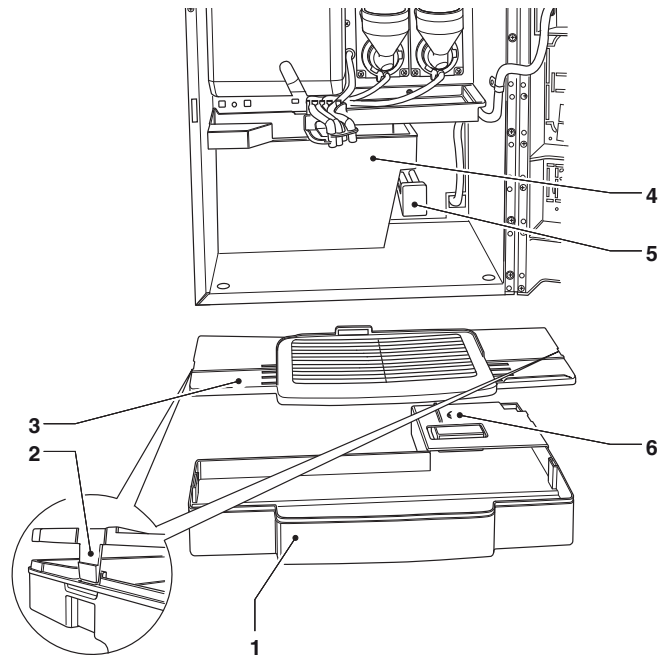

Fig. 8

- 1- Container for gathering liquid waste
- 2- Cover fixing hooks
- 3- Container Cover
- 4- Solid residue container
- 5- Full waste float switch
- 6- Full waste float

WASTE RESET PASSWORD

In order to reset the selections counter, it is necessary to press some buttons in sequence (enter a password);

With the closed door, proceed as follows:

- Press and hold button no. 9 for two seconds
- The management software will ask you to enter a password and the keyboard adopts the numerical values shown in the figure below.

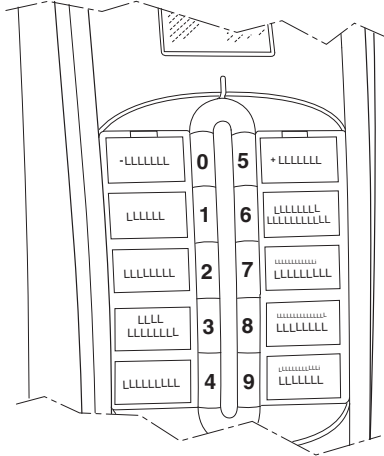

Fig. 9

DISPENSING UNIT

When cleaning the dispensing unit, it is recommended to remove it from the machine.

- Remove the saw tooth screws and the fixing screws of the unit;
- Unfasten the unit by acting on the fixing fins;
- Wash with a solution of neutral detergent, being particularly careful with the covers of the cup sensor and of the unit lighting LEDs.
- Dry carefully and reassemble following the reverse order

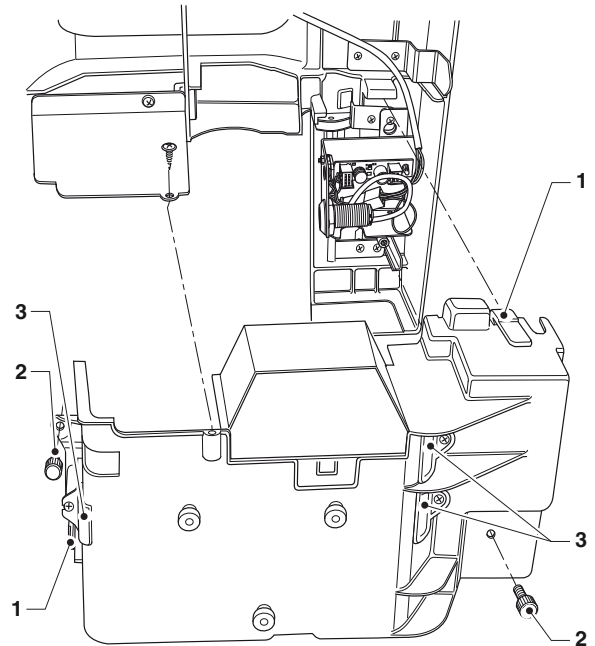

Fig. 10

- 1- Fixing fins
- 2- Saw tooth screws
- 3- Sensors

PERIODICAL CLEANING OF THE INFUSER UNIT

Each time the vending machine is loaded, or at least every week, it is good practice to clean the external parts of the infuser unit from any coffee residue and particularly in the coffee drop areas, of the filters and scrapers

Warning!

After removing all traces of powder from the unit, it is advisable to wash the infuser unit.

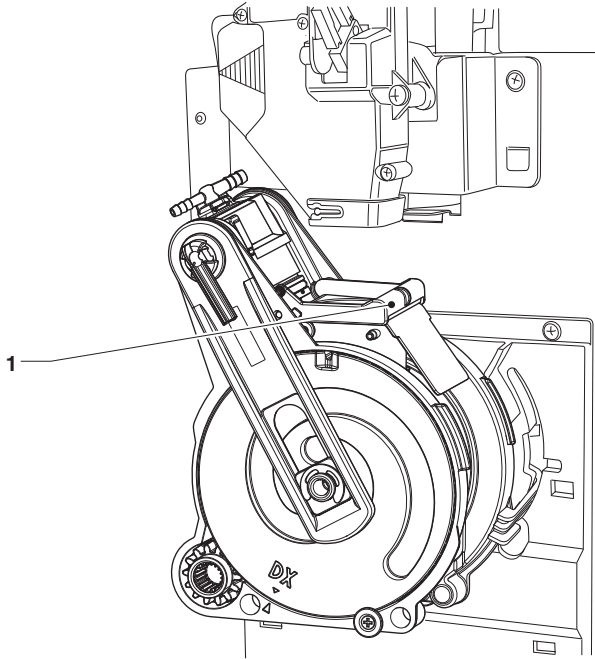

Fig. 11
1- Scraper

CLEANING OF THE WATER SUPPLY TANK (Optional)

For the machines which use the water tank, it is necessary to carry out, at least on a weekly basis, the sterilisation of the tank by using the sterilising products used for the mixers. Thoroughly wash the tank taking care to mechanically remove visible residues and films using swabs or brushes, if necessary

START-UP

Every time the machine is connected to the power supply, the display will show the image



after that, the vending machine software version number is displayed together with the software review of the machine board.

It is possible to programme the machine for displaying, for a few seconds, the number of dispensed items (total number of strokes)

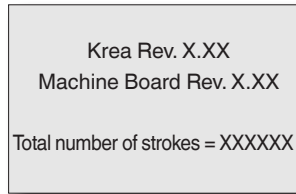

After that, the boiler is checked and the heating cycle is started

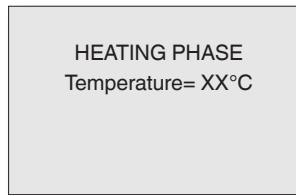

At the end of the heating cycle, after a few seconds, the display shows the message with the invitation to select the drink and the lighting of the machine is activated.

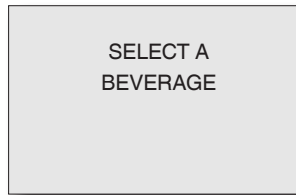

PASSWORD INPUT WITH CLOSED DOOR

In order to safely perform some of the cleaning operations which require the machine to be in operation, it is possible to use the selection buttons in sequence (password).

The password input with closed door allows the performance of the operation associated with the entered password, which means:

- Wash the mixer
- Wash the infuser unit
- Reset the waste counter

To enter the password with closed door, proceed as follows:

- Press and hold button no. 9 for two seconds.
- The management software requests the input of a password, the keyboard assumes the numeric values shown in the figure.

The machine remains in standby for a few seconds for the input of the password (5 digits) which allows you to perform the operation associated with the entered password.

These passwords can be defined in the Engineer Menu. By default, all the passwords are disabled.

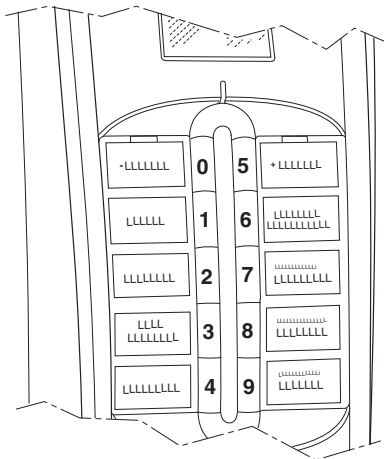

Fig. 12

SERVICE SUSPENSION

If, for any reason, the vending machine remains off for a period longer than the expiry dates of the products, it is necessary to:

- Completely empty the containers and wash them carefully with the sterilising products used for the mixers.
- Sanitize the mixers
- Completely empty the grinder-doser by dispensing coffee until the notification that the machine is empty.
- Completely empty the hydraulic circuit.

Chapter 2 Installation

The installation and the subsequent maintenance operations shall be carried out with the **machine connected to the power supply** and therefore by specialised personnel, trained for the use of the machine who has been informed of the specific risks deriving from such a situation.

When the door is open, voltage is given to the machine by inserting the appropriate key. The door can be closed only after extracting the yellow key from the door switch and the top of the machine has been lowered.

The machine should be installed in dry premises, with a temperature between 32 and 104 °F.

When the machine is installed, the hydraulic circuits and the parts in contact with the food products need to be sterilised in order to eliminate any bacteria which could have formed during storage.

DOOR SWITCH

When the door is opened, a microswitch removes the voltage from the electrical system of the machine. When the door is open, voltage is given to the machine by inserting the appropriate key.

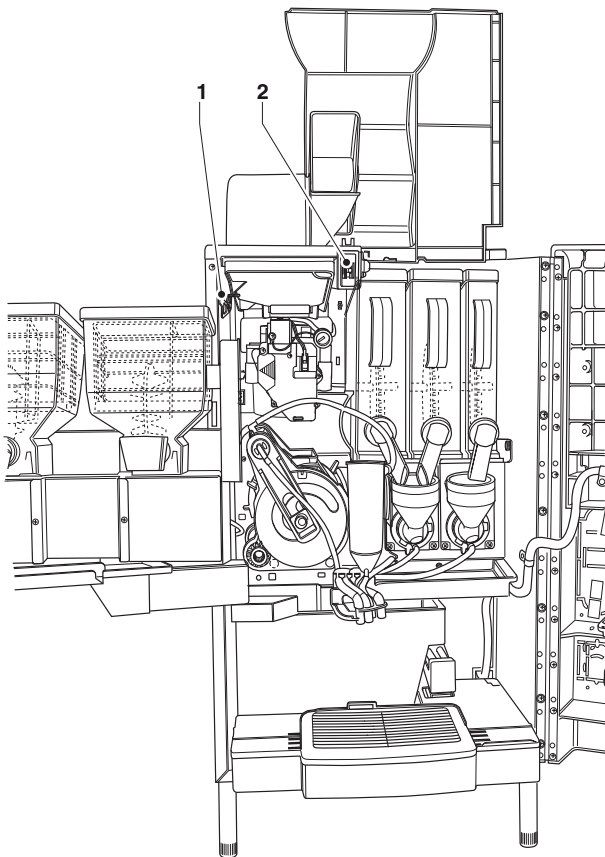

Fig. 13

- 1- Upper panel closure control device
- 2- Door switch

With the door open, there is no access to live-parts. Inside the machine, only those parts which are protected by covers and which are highlighted with a label "disconnect voltage before removing the cover" remain live.

Before removing these covers it is necessary to disconnect the power supply cable from the mains.

The door can be closed only after removing the key from the door switch, lowering the upper panel of the machine and closing the opening of the coffee container so that the closure control devices are enabled.

UNPACKING THE VENDING MACHINE

After removing the packaging, verify the integrity of the machine.

In case of doubt, do not use the machine.

The packaging materials (plastic bags, expanded polystyrene, nails, etc.) shall be kept out of the reach of children as they are a potential source of danger.

The packaging materials need to be disposed of in authorised places. Recycling materials shall be given to specialised recycling companies.

POSITIONING OF THE VENDING MACHINE

The machine shall be positioned next to a wall and in such a way that the back of it is at a minimum distance of 2 cm from the wall in order to allow regular ventilation. The machine shall not be covered with cloths or similar.

Important

The machine shall be positioned so that the maximum inclination does not exceed 2°.

The appliance satisfy the requirements NSF only when are used 100 mm's feet

Important

In the event of unscheduled maintenance interventions and/or repairs, the vending machine can be accessed from the back.

The possibility should therefore be envisaged of rotating the machine so that the back panel can be removed.

INSERTING THE PLATES

Remove the fixing screw and remove the cover.

The plates need to be inserted into the appropriate slots. Based on the models, some buttons could be disabled (see doses-selections table).

The machine is supplied with self-adhesive plates which shall be attached to the products containers based on layout (see doses-selections table)

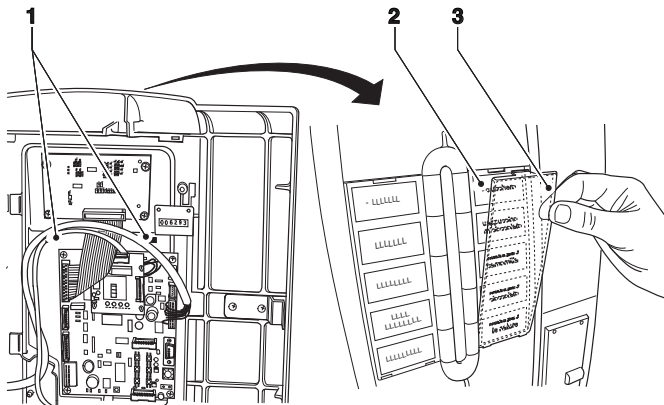

Fig. 14

- 1- Fixing fins
- 2- Plates support
- 3- Selections plates

PAYMENT SYSTEM

The machine is sold without a payment system, therefore whoever performs the installation of it bears the responsibility for any damage to the machine or to objects and people deriving from the wrong installation of the payment system.

The validator can be installed directly into the machine. Ensure that the programming of the related parameters is correct.

The “cashless” systems can be placed into the machine; other payment systems such as “change giver” shall be physically placed inside the support cabinet or in the lateral module (optional).

The use of payment systems such as “change givers” and/or “cashless” is possible only using the appropriate connection kits.

WATER SUPPLY

The water used by the vending machine is drinking water, using a backflow protection and taking into account the regulations in force where the machine is installed.

The machine should be connected to the drinking water mains with water pressure between 7.3 psig and 123.3 psig (0,5-8,5 bar).

Let the water come out from the mains until it is clear and free from dirt.

Connect the water mains to the 3/4” connection of the water inlet solenoid valve with a pipe having minimum internal diameter of 6 mm (also available as a kit), suitable for supporting the mains pressure and of a type suitable for food products.

Installing a tap on the water system outside the machine, in an accessible position, is recommended.

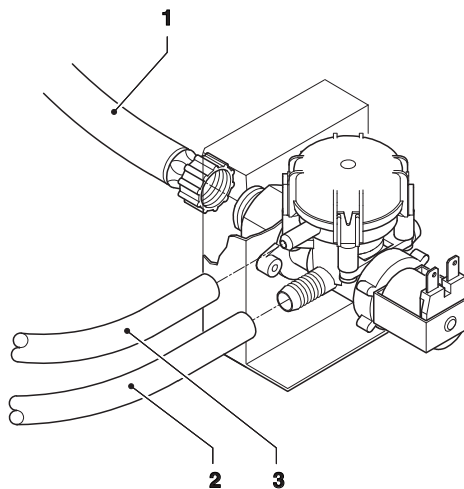

Fig. 15

- 1- 3/4” inlet tube
- 2- Inlet tube
- 3- Overflow tube

ANTI-FLOODING DEVICE

The water inlet solenoid valve is equipped with an anti-flooding device which allows the mechanical blocking of the input of water following a malfunction of the solenoid valve or of the control system of the level of water in the boiler.

For restoring the normal operations, do as follows:

- empty the water contained in the anti-flooding pipe;
- close the water mains tap outside the machine;
- loosen the connection which fixes the input pipe of the solenoid valve for lowering the residual water pressure and tighten it again;
- open the tap and apply voltage to the machine.

DESCALER

The machine is supplied without descaler.

In the event that the machine is connected to very hard water, it is necessary to install a descaler.

Use descalers with a capacity which is adequate to the actual use of the machine.

In case the machine uses a water tank, it is possible to use appropriate filtering cartridges.

The cartridges will need to be replaced periodically depending on the water quality and the indications given by the manufacturer.

The descalers, also available as an accessory, need to be periodically regenerated or replaced according to the manufacturer's instructions.

ELECTRICAL CONNECTION

The machine requires a single phase voltage of 120 V~ and it is protected by a 15 A fuse.

For the connection, make sure that the plates data correspond to the mains data, and in particular: The value of the voltage shall be within the recommended limits;

it is mandatory to use a switch, in accordance with current the installation standards, located in an accessible position, which has characteristics suitable for supporting the maximum load and ensures the complete disconnection from the power supply under conditions of overvoltage category III and, therefore, which protects the circuit against ground faults, overloads and short circuits

The switch, the socket and the plug shall be placed in an accessible position.

The electrical safety of the machine is ensured only when the machine is correctly connected to an efficient earthing system, as foreseen by the current safety regulations.

It is necessary to verify this fundamental safety requirement and, in case of doubt, request an accurate check of the system by qualified personnel.

The use of adapters, multiple plugs and/or extension cables is forbidden.

The manufacturer shall not be held responsible for any damage caused by the non-observance of the above-mentioned precautions.

LINE CABLE REPLACEMENT

The power supply cable has a non-separable plug; The replacement of the connection cable shall be carried out only by qualified personnel and using only cables of the type SJTW 14AWG /3C 105 °C BLACK with NEMA 5-15P certified plug.

To replace the cable, after disconnecting the device from the power supply, it is necessary to open the hinged lid and connect the new cable.

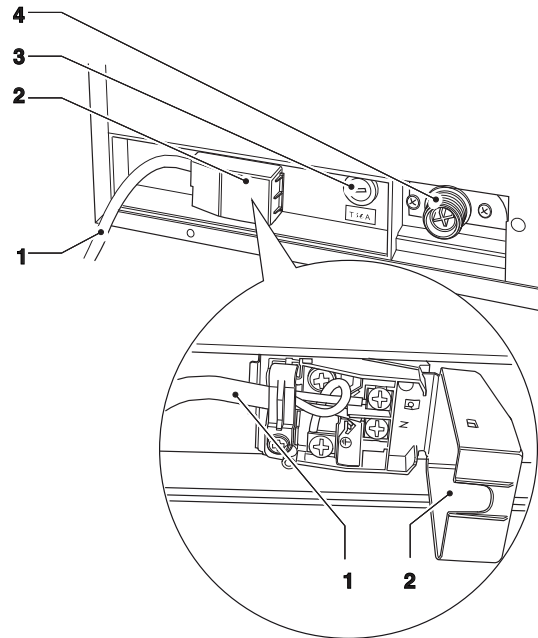

Fig. 16

- 1- Mains lead
- 2- Flip cover
- 3- Mains fuse
- 4- Water inlet

FIRST START-UP

At the first start-up of the machine, it is necessary to fill the hydraulic circuit (installation).

The filling procedure varies depending on whether the machine obtains its water supply from a tank.

WATER SUPPLY FROM MAINS

- Upon start-up, the mains solenoid valve is opened automatically until the air-break is filled.
- The solenoid valve of the boiler opens to release the air in the boiler and the hydraulic circuit.
- During the entire cycle, the display will show "INSTALLATION"

Note: In case of lack of water during the installation cycle, the machine will stop and wait for the water.

If substantial water pockets form in the hydraulic circuit, then the hydraulic circuit must be filled using the special "manual installation" function

WATER SUPPLY FROM TANK

- Upon start-up; the water pump is activated for 10 seconds
The display shows the "water empty" message
- Enter the "Engineer" programming mode and use the special function "Manual installation" of the "Test" menu.
The machine performs an installation cycle
- When the installation cycle terminates, reset the fault message "empty water"

After the hydraulic circuit has been filled, the display will show the message:

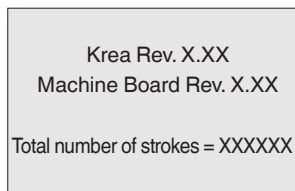

After the initial checks, the boiler heating cycle is started.

At the end of the heating cycle, after a few seconds, the display shows the message inviting the user to select the drink and the keyboard lighting is activated.

FIRST STERILISATION OF THE MIXERS AND OF THE FOOD PRODUCT CIRCUITS

When the machine is installed it is necessary to carry out an accurate sterilisation of the mixers, of the instant drinks dispensing pipes and of the internal tank in order to ensure the hygiene of the distributed products.

Jets of water are to be absolutely avoided for cleaning.

The sterilisation is performed by means of sterilising products.

Wash the mixers and add a few drops of sterilising solution. Once the sterilisation has been performed, rinse the mixers well for removing any possible residue of the solution used. For letting water inside the mixers, use the button "mixer wash"; if necessary, enable it from the menu. (see the paragraph related to the vending machine parameters)

Important!

The machine is equipped with an automatic washing system for the mixers with relative hydraulic circuit and the infuser unit.

If the use of the machine is subject to idle periods (weekends, etc.), even for less than two days, it is good practice to enable the automatic washing functions (before beginning to use the DA for example) (see "Engineer menu - Configuration - Mixer wash and Infuser unit wash")

OPERATION

INFUSER UNIT

After each start-up of the machine, the infuser unit performs a full rotation before performing the normal cycle in order to ensure that the device is positioned in the initial position.

The infuser can dispense espresso drinks (coffee beans) and fresh brew (pre-ground coffee or tea)

DISPENSING CYCLE

By requesting:

- an espresso selection the grinder is activated until the coffee doser chamber is full.

When the doser is full, the coffee dose is released into the infusion chamber which is located vertically inside the infuser unit.

or

- a fresh brew selection, the pre-ground portion of the product is dispensed directly into the infuser unit.

The gear motor engaged on the pinion lets the cranks rotate, which cause the infusion chamber to rotate by 30° as well.

The upper piston aligns itself with the infusion chamber and descends inside it.

The position where the piston stops for the infusion

- will depend on the quantity of ground coffee in the infusion chamber for the espresso selections

or

- it will be fixed and in the highest possible position in the infusion chamber (low infusion pressure) for the fresh brew selections

Depending on the requested selection, the beverage will come respectively from the espresso nozzle or the fresh brew nozzle.

At the end of the dispensing phase, the upper piston goes down in order to mechanically squeeze the coffee pod, facilitating the expulsion of excess water through the 3rd route of the dispensing solenoid valve.

At the end of the cycle the gear motor is activated in the opposite direction, lifting the upper piston and rotating the infusion chamber towards the emptying side, on the opposite side of the dispensing side; the lower piston rises.

Once the emptying position is reached, the gear motor inverts its rotation direction again, bringing the infusion chamber back to the idle position.

The scraper holds the coffee pod and lets it fall, while the lower piston returns to the idle position.

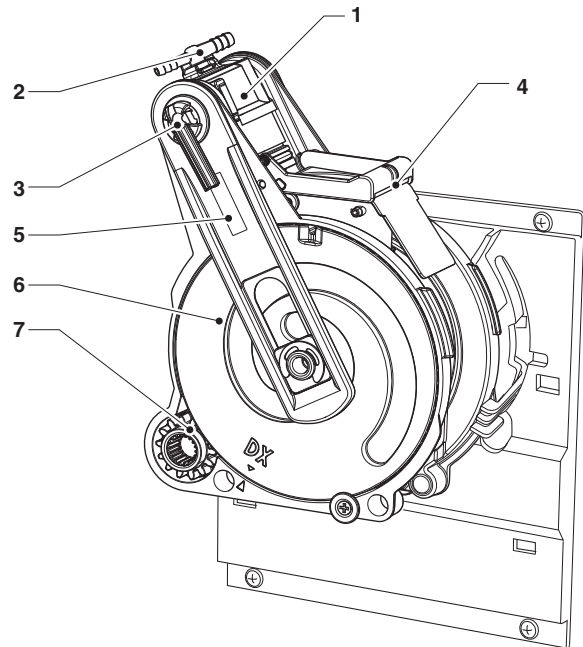

Fig. 17

- 1- Upper piston
- 2- Fresh Brew nozzle
- 3- Espresso nozzle
- 4- Scraper
- 5- Rods
- 6- Cranks
- 7- Pinion

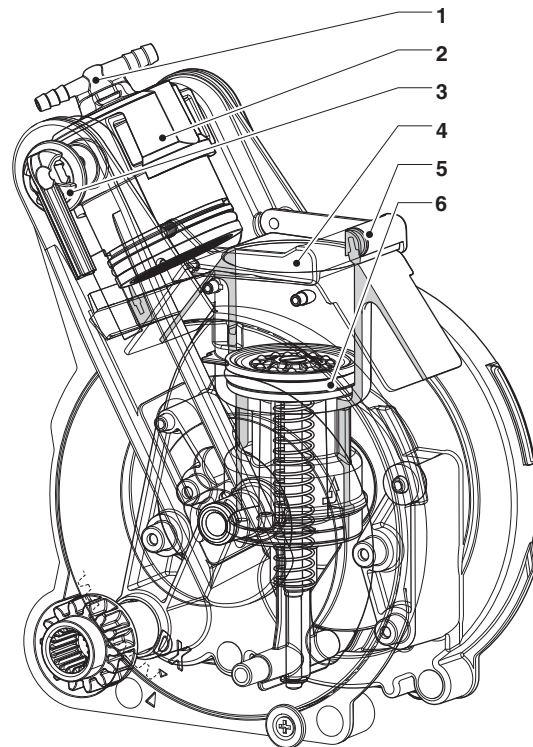

Fig. 18

- 1- Fresh Brew nozzle
- 2- Upper piston
- 3- Espresso nozzle
- 4- Infusion chamber
- 5- Scraper
- 6- Lower piston

VOLUME OF THE INFUSION CHAMBER

The infuser unit can operate with coffee doses between 0.26 and 0.53 oz (7.5 to 15 gr).

The upper piston will position itself automatically, depending on the requested selection (espresso or fresh brew)

CHECKS AND SETTINGS

To obtain the best results for each product used, we recommend the following checks:

- The coffee pod shall be slightly compressed and moist.
- The grain size of ground coffee.
- The grammage of ground coffee.
- The dispensing temperature.
- Dose of water.

CUP SENSOR (OPTIONAL)

Only some machines are equipped with a cup sensor which detects the presence of objects between the reflector and the sensor.

To ensure correct operation, the emitter and the protective glass of the reflector in front of it must be kept clean.

DISPENSING UNIT LIGHTING (OPTIONAL)

Only some machines are equipped with LEDs for lighting the dispensing unit.

By default, the LEDs switch on when the drink is being dispensed and remain on for a few seconds after the end of the dispensing; however, the on time or steady-on of the LED can be programmed.

BUTTON LEDs

The selections menu has variable colour LEDs.

During the heating or energy saving phases the LEDs are off.

During the normal operation of the machine, the LEDs are on; the colour can be chosen through the appropriate function of the engineer menu.

GRINDER-DOSER

The adjustments / settings for the grinder-doser are valid only for the selections based on coffee beans

GRINDING SETTING

If the grinding grade needs to be changed, adjust it using the relevant knob on the grinder, and more precisely:

- rotate the knob anti-clockwise to obtain coarser grinding;
- rotate the knob clockwise to obtain finer grinding.

It is good practice to change the grinding grade when the coffee grinding motor is working.

Note: after varying the grinding grade, it is necessary to carry out at least 2 selections for checking the new ground coffee grain size:

The finer the grinding grade, the longer the dispensing time will be and vice versa.

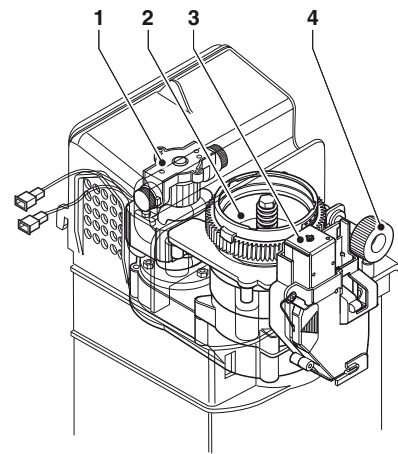

Fig. 19

- 1- Grinder motor
- 2- Grinder
- 3- Coffee release electromagnet
- 4- Grinding adjustment knob

VARIABLE-DOSE COFFEE DOSER

A coffee dose is composed of two quantities of ground coffee, released consecutively from the doser. The doser can be set to dispense two different quantities of ground coffee;

- a first quantity, volume-dosed (more precise), is released upon the filling of the doser chamber;
- the second quantity, time-dosed, adjustable in percentage (from 1 to 99%) of the volumetric amount grinding time, is released when the set time is achieved. If the percentage is set to 0 only one release is carried out; if the percentage is set to 100 two volume-dosed releases are carried out (filling of the chamber also for the second release).

The chamber volume of the variable-dose doser can be adjusted between 0.18 and 0.30 oz (5.1 to 8.5 gr). using the adjustment lever.

The dose adjustment lever can be positioned on one of the 10 reference notches, taking into consideration that:

- raising the lever increases the dose:
- lowering the lever decreases the dose:
- each notch changes the dose by approx. 0.01 oz (0,4 gr.)

DOSE SETTING

Four different doses are managed on the doser: one low dose (e.g., for a single coffee), two intermediate doses and one high dose (e.g., for a double coffee).

The coffee unit can accept up to 0.53 oz (15 gr) of coffee.

- If you opt for the completely volumetric high dose (100% time - two releases), you must not exceed 0.21 oz (6 gr) adjustment for the volume of the dispenser. In this case, the dose for single coffee will be composed of 0.21 oz (6 gr volume) plus the grams ground in the programmed time (volume grinding other than 100%).
- If you opt for the totally volumetric low dose, you will need to adjust the volume to the desired dose with the addition of 0% time-ground gr. In this case the intermediate doses and the highest dose will be composed of the volume-dosed grams with the additions of the grams ground in the programmed time (volume grinding other than 0%).

Warning! If the position of the adjustment lever is changed, the percentage value of the added dose will have to be reset.

Important!

Test releases can be performed using the appropriate function of the "Test" menu in the "Technical" mode (see relevant paragraph); the released doses should be collected by removing the infuser unit in order to prevent the leakage of coffee inside the machine.

The layouts provide for a combination between the selections and the dose which, in any case, can be changed.

It is possible to modify the combination of the doses and selections determined based on the product used and the desired beverage quality.

The default setting of the machine is indicated in the doses-selections table supplied with the machine.

COFFEE DOSE COMBINATION

Even though this combination can be changed, the choice to do so should be made very carefully since it has a substantial effect on the quality of the dispensed drink.

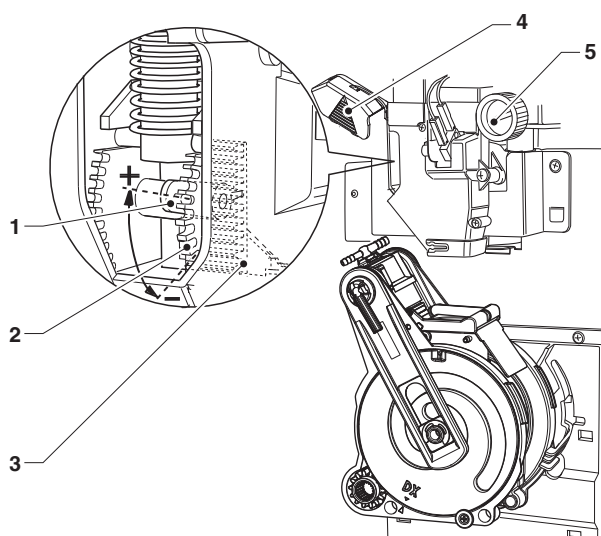

Fig. 20

- 1- Dose adjustment lever
- 2- Reference notches
- 3- Dose adjustment
- 4- Coffee dose adjustment cover
- 5- Grinding adjustment knob

INSTANT DRINKS DISPENSING

The dispensing cycles of the various selections are studied for obtaining the best result in terms of productivity and quality of the drinks.

The instant drinks are dispensed following a recipe in which the ingredients (max 4) are identified with a number and the product name and described by the water and product quantities and the dispensing and mixing times.

These values are programmable via software with appropriate functions.

Even the dispensing order of the individual ingredients within a recipe is programmable.

The powder for chocolate-based selections is dispensed intermittently, whereas the powder for coffee-based selections is dispensed before the water.

Warning !!!

Make sure that the mixer is rinsed correctly without leaving any powder residue.

PRESELECTIONS

Based on the layout that has been set on the machine, it is possible to have different preselections; the preselections foreseen for each layout are described in the doses-selections table (layout selections) supplied with the machine.

DOSERS CALIBRATION

For the correct conversion of the amounts of the product dose it is possible to set the value of the rate of each of the dosers in g/sec for calculating the grams to be dispensed.

ADJUSTMENT OF THE WATER TEMPERATURE

The temperature of the boiler is controlled by the software:

The default value is 199.4° F for the boiler and it can be adjusted directly from the menu.

VARIATION OF THE SETTING FOR INSTANT PRODUCTS

The grammage of the instant products, the dose of water and the temperature are controlled directly by the micro-processor.

The variation of these values is therefore performed through the programming procedures.

Notes about Programming

The electronic control unit of the machine controls the use of many functions.

The programme of the machine contains a description of all the foreseen functions, including those which, for the specific configuration of the model (layout), are not used. The machine is supplied together with:

- Selections layout, which contains the selections foreseen for the specific model
- Flow chart of the programming menu.

Described below is a summary of the main functions which are useful for managing the operation of the machine, not necessarily in the order in which they are displayed in the menu.

The software version can be updated using the appropriate systems (PC, Giga, UpKey, etc.)

The display messages which show the operation in progress are steady-on, while any action requested of the user flashes.

The status of the machine can be in three different modes.

Depending on the status in which the machine is, the buttons of the keyboard assume different functions.

NORMAL USER

- Machine start-up (door closure) with the execution of the foreseen checks.
- Operations that can be done with the door closed.
- Dispensing selection and messages to the user.

LOADER MENU

- Detection of statistical data and execution of simple checks on the operation and on the dispensed items.

TECHNICAL MENU

- Programming of the settings and performance of the machine, divided into two levels:

OPERATION IN NORMAL USER STATUS

During the normal operation, the display shows the message to the user and the invitation to select the drink.

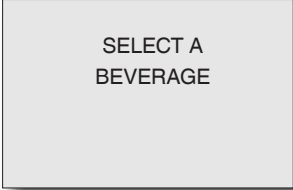

SELECT A
BEVERAGE

When the drink is being dispensed, an animation is shown which indicates the stage of preparation of the drink.



IN PREPARATION

In the event that an anomaly is detected by the control system, an error message will be given, indicating the type of problem:

Depending on the settings, the lighting of the keyboard may be red

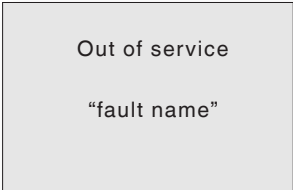

Out of service

"fault name"

At the end of the dispensing phase, the display shows the following message for a few seconds:



READY DRINK

COLLECT

NAVIGATION

ENTERING THE PROGRAMMING MODE

The programming menu can be entered by switching the machine on with the door open, acting on the door switch.

For entering the programming mode press the button “programming access” inside the door of the machine: The machine status changes to “loader menu”, use the key **←** for switching from the “loader menu” to the “engineer menu” and vice versa.

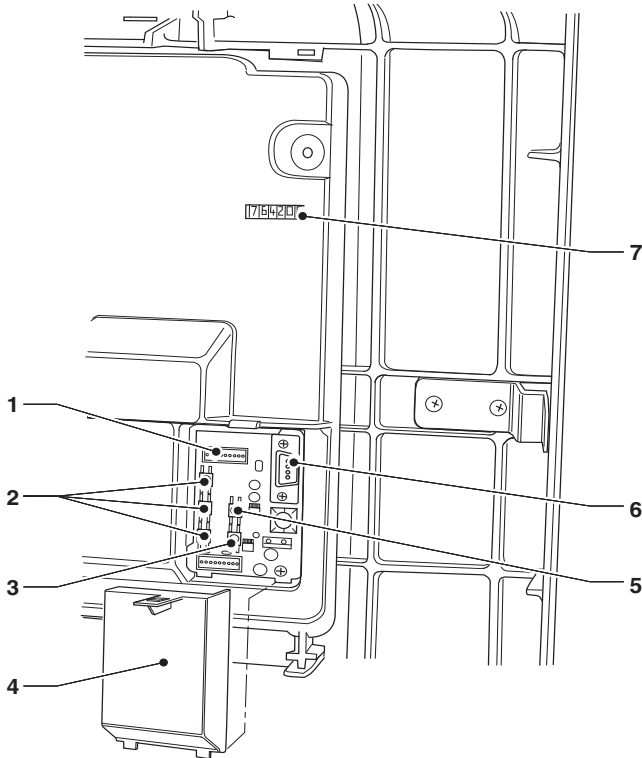

Fig. 21

- 1- UpKey connector
- 2- Buttons with programmable function
- 3- Programming input button
- 4- Buttons cover
- 5- Faults reset button
- 6- RS232 serial connector
- 7- Mechanical strokes counter

The interaction between system and operator is through:

DISPLAY

8 rows display which shows the messages to the users or the items of the menu.

The programming menu is represented as follows:

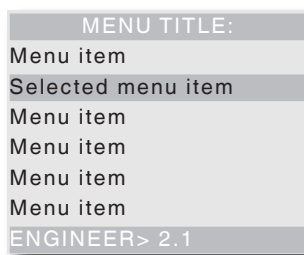

MENU TITLE:

if requested, this is shown on the first row, followed by the available menu items.

Selected menu item

The item of the menu where the cursor is positioned

ENGINEER> 2.1

This shows the current active menu (Loader or Engineer) followed by the numerical position of the function on which the cursor is positioned (i.e. 2.1)

KEYBOARD

With the machine in “Loader” or “Engineer” mode, the selection keyboard assumes the functions:

NAVIGATION KEYS **↓** AND **↑** :

These keys allow you to navigate between the items of the menu (functions).

Within a function, they allow you to vary, where requested, the logical status of data (ON/OFF), or enter/modify alphanumeric values.

CONFIRMATION KEY **↵**:

This allows you to switch from a menu to a submenu or to confirm the data shown on display.

EXIT KEY **←**:

This allows you to return from a submenu to the menu of higher level, or to cancel the function.

It also allows you to switch from the “Engineer” to the “Loader” mode and vice versa.

KEYS FOR NUMERIC VALUES

When the control software requests the input of a password, the keyboard assumes the numeric values shown in the figure.

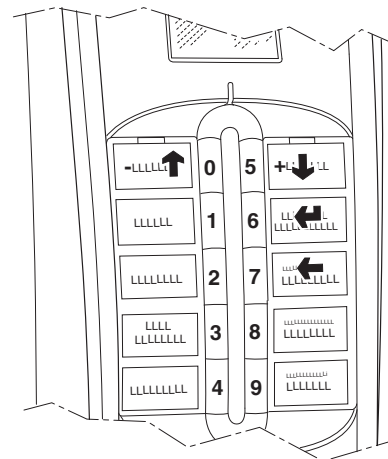



Fig. 22

LOADER MENU



When the programming button located inside the door is pressed once, the machine goes into "loader menu" mode.

The display shows the first item of the "Loader" menu with the available operations.

The last row of the display contains the menu and the number, which allow you to identify the current level.

By pressing the confirmation key  you can access the menu.

By pressing the exit key  you go back to the previous menu.

The keys  and  allow you to navigate through the items of the menu:

STATISTICS

All the data related to the operation of the machine is stored both in total counters and in relative counters, which can be reset without losing the total data.

PRINTING

This function allows you to print the stored data related to the operation of the machine

By connecting an RS232 serial printer with a baud rate of 9600, 8 data bits, parity of None and 1 stop bit to the serial port on the button board, it's possible to print all the statistics and in particular:

TOTAL



- 1 - selections counter;
- 2 - bands counter;
- 3 - discounts counter;
- 4 - faults counter;
- 5 - coin box data.

RELATIVE

- 1 - selections counter;
- 2 - bands counter;
- 3 - discounts counter;
- 4 - faults counter;
- 5 - coin box data.

The printout also shows the code of the machine, the date and the software version.

The printout can be obtained as follows:

- From the printing function press the key  the display shows "Confirm?";
- connect the printer;
- press the confirmation key  for printing

DISPLAY

This function allows you to display in a sequence the same statistics data that can be obtained with the printout.

Press the confirmation key  for displaying the data in a sequence of the:

TOTAL COUNTERS

- 1 - selections counter;
- 2 - bands counter;
- 3 - discounts counter;
- 4 - faults counter;
- 5 - coin box data.

RELATIVE COUNTERS

- 1 - selections counter;
- 2 - bands counter;
- 3 - discounts counter;
- 4 - faults counter;
- 5 - coin box data

RESETTING

The relative counter statistics can be reset globally, for all types of data, or selectively for:

- selections
- discounts
- faults
- coin box data

By pressing the confirmation key  the display will show the flashing message: "Confirm?"

Press the confirmation key  for resetting the statistics, during the operation the display shows the message "Execution" and the statistics are reset.

INDIVIDUAL PRICE

This function is active only if the machine has a payment module.

The machine can manage up to 4 different prices for each selection, which can be active depending on the time band that has been set (standard or promotional) and/or on the payment system used.

Through this function it is possible to vary the sales price for each selection, selecting among the available price bands.

MANAGEMENT OF THE COIN BOX TUBES

This function is active only if the machine has a payment module.

By entering into this function it is possible to manually load or empty the coin mech tubes.

By confirming the loading operation, the display shows “Credit : —” which is the amount of money in the tubes available for being returned; if you introduce the coin in the validator, the display will increase the amount of money in the tubes which is available for being returned.

By confirming the emptying operation, it is possible to establish on which of the tubes to intervene. Every time the confirmation key is pressed , a coin is ejected from the active tube.

BOILER TEMPERATURE

This function allows you to read, directly in °C, the temperature detected in the boiler.

TEST

For complete or partial dispensing tests, each button (or combination of keys, depending on the models) activates the corresponding selection (see doses-selections table).

Please note For the espresso-based selections, with the partial dispensing of powder and water only the additions are dispensed; if the selection does not foresee additions, the display will show “Selection Disabled”

The possible test dispensing are:

- Complete dispensing
- Dispensing of only water
- Dispensing of only powder
- Dispensing without accessories (without cup, stirrer and sugar)
- Dispensing of accessories only (not available for this model)

EVA DTS

EVA DTS communication protocol (European Vending Associations Data Transfer System) allows the communication with statistics acquisition devices.

CONNECTION

By activating this function, the machine waits for the connection with a statistics activation device EVA DTS.

ALERT COUNTERS RESET

This function is used to reset all the counters which manage the “product running out” alerts.

Press the key  to reset.

PARTIAL RESET

This function allows you to reset the counter which manages the “product running out” alert of a single product.

Press the key  to reset.

ENGINEER MENU

Below is an explanation of the main software functions which manage the operation of the machine, grouped by logic of use and not necessarily in the order in which they are displayed in the menu.

The software version can be updated using the appropriate systems (PC, Giga, UpKey, etc.)

For more information and details please refer to the doses table supplied with the machine, taking into account the software version of the machine.

By pressing the key **←** from the "Loader" mode, the machine goes into "Engineer menu" mode.

The display shows the first item of the "Engineer" menu with the available operations.

The last row of the display contains the menu and the number, which allow you to identify the current level.

- By pressing the confirmation key **↵** you can access the menu.
- By pressing the exit key **←** you go back to the previous menu.
- The keys **↑** and **↓** allow you to navigate through the items of the menu.

Notes:

If you want to go back to the Loader mode, press the key **←** from any first level function.

PAYMENT SYSTEMS

This function is active only if the machine has a payment module.

It is possible to decide which of the protocols for the expected payment systems to enable and manage the related functions.

The communication protocols for the expected payment systems are: Validators, Executive, BDV, MDB

Some of the parameters, which are common among several payment systems, keep the set value even if the system type is changed.

If necessary, they can be modified from the menus of the payment systems.

VALIDATOR

CHANGE IMMEDIATELY

Usually the amount related to a selection is cashed in after the machine sends the signal "Selection made".

By enabling this function, which is disabled by default, the payment signal is sent at the beginning of the dispensing.

Setting this parameter is compulsory.

DECIMAL POINT POSITION

Pressing the confirmation key **↵** displays the position of the decimal point, in particular:

- 0 decimal point disabled
- 1 XXX.X (one decimal place)
- 2 XX.XX (two decimal places)
- 3 X.XXX (three decimal places)

By pressing the confirmation key **↵**, these values flash and they can be modified.

RESERVATION TIME

For cash payment it allows to set how long the machine will display the remaining credit to be entered in order to dispense the selection (default 7 seconds)

LINE/VALUE ASSOCIATION

When the display is positioned on the function "LINE-VALUE ASSOC." (line programming) of the "programming" menu, it is possible to vary the value of the 6 coins lines, from A to F, of the validator.

CREDIT PROGRAMMING (OVERPAY)

You can decide whether to:

- collect any credit in excess of the amount of the selection after a certain time in seconds (parameter "deleted 000")
- leave any credit in excess of the amount of the selection available for a subsequent selection (parameter "kept")

EXECUTIVE

COIN BOX VERSION

For the Executive system, you must choose from among the following payment systems:

- Standard
- Price holding
- UKEY (Price holding price display)

CHANGE IMMEDIATELY

Usually the amount related to a selection is cashed in after the machine sends the signal "Selection made". By enabling this function, which is disabled by default, the payment signal is sent at the beginning of the dispensing.

Setting this parameter is compulsory.

RESERVATION TIME

For cash payment it allows to set how long the machine will display the remaining credit to be entered in order to dispense the selection (default 7 seconds)

BDV

The BDV protocol menus allow you to define the following functions.

IMMEDIATE CHANGE

Usually the amount related to a selection is cashed in after the machine sends the signal "Selection made". By enabling this function, which is disabled by default, the payment signal is sent at the beginning of the dispensing.

Setting this parameter is compulsory.

RESERVATION TIME

For cash payment it allows to set how long the machine will display the remaining credit to be entered in order to dispense the selection (default 7 seconds)

TYPE OF DISPENSING

This allows you to set the operating mode for multiple or single dispensing. With multiple dispensing, the change is not automatically returned at the end of one dispensing, but it remains available for further dispensing. When the coins return button is pressed, the remaining credit will be returned if its value is less than the maximum change value.

CREDIT RETURN (ESCROW LEVER)

This allows the enabling/disabling of the return of the credit (pressing the change return key) if no dispensing was made.

If enabled, this function allows the coins to be returned even if the first dispensing has not occurred.

But if a dispensing failed for any reason, if requested, the change will be paid.

MAXIMUM CREDIT

This function allows you to define the maximum credit for the introduced coins which is accepted.

MAXIMUM CHANGE

It is possible to set a limit to the total amount of the change that the coin box will pay when the change return button is pressed or after a single dispensing.

Any credit exceeding the programmed amount with this function will be cashed in.

ACCEPTED COINS

It is possible to define which coins among those recognised by the validator shall be accepted.

In relation to the coin/value correspondence, the label on the coin box shall be checked, which shows the position of the coins.

ACCEPTED CHANGE COINS

This allows you to program the refusal of coins if the condition "exact amount" is met.

In relation to the coin/value correspondence, the label on the coin box shall be checked, which shows the position of the coins.

EXACT CHANGE EQUATION

This data defines the combination of empty tubes which puts the coin box in the condition of "exact amount". The possible combinations of empty tubes are shown below. For simplicity reasons the combination is described with reference to the tubes A, B and C, where tube A receives the lower value coins and tube C the higher value coins.

0	=	A or (B and C)
1	=	A and B and C
2	=	only A and B
3	=	A and (B or C)
4	=	only A
5	=	only A or B (default)
6	=	A or B or C
7	=	only A or B
8	=	only A or C
9	=	only B and C
10	=	only B
11	=	only B or C
12	=	only C

DISPENSING BUTTONS

This function allows you to enable or not the buttons on the coin box for removing the coins from the coin box tubes.

C.P.C. UNIT

It communicates to the coin box if some peripherals have been installed or removed from the serial connection (C.P.C. type peripherals - the default verification unit is always enabled).

RETURN EXACT CHANGE (MINIMUM HOSE LEVEL)

This allows the user to be notified with the message "Insert exact amount", adding a number of coins between 0 and 15 to the programmed number of coins for determining the full status of the tubes.

VMC FREE SALE

Most of the payment systems with BDV protocol manage the free sale function.

Nevertheless, there are payment systems which do not have this function.

In this case, having to dispense some selections free of charge, it is necessary to enable the VMC free sale (vending machine control, enabled by default) and set the price of these selections to zero.

MDB

The MDB protocol menus allow you to define the following functions.

CHANGE IMMEDIATELY

Usually the amount related to a selection is cashed in after the machine sends the signal "Selection made". By enabling this function, which is disabled by default, the payment signal is sent at the beginning of the dispensing.

Setting this parameter is compulsory.

DECIMAL POINT POSITION

Pressing the confirmation key  displays the position of the decimal point, in particular:

- 0 decimal point disabled
- 1 XXX.X (one decimal place)
- 2 XX.XX (two decimal places)
- 3 X.XXX (three decimal places)

By pressing the confirmation key , these values flash and they can be modified.

Setting this parameter is compulsory.

RESERVATION TIME

It sets for how long the machine will display the remaining credit to be entered in order to deliver the selection (default 7 seconds)

TYPE OF DISPENSING

This allows you to set the operating mode for multiple or single dispensing. With multiple dispensing, the change is not automatically returned at the end of one dispensing, but it remains available for further dispensing.

When the coins return button is pressed (if the function is enabled), the remaining credit will be returned up to the maximum change value.

Obligation to buy This allows the enabling/disabling of the coins return button before dispensing a product.

- ON: the change is returned after a product has been selected

- OFF: the change is returned immediately when the coins return key is pressed (the machine works as change machine)

MAXIMUM CREDIT

This function allows you to define the maximum credit for the introduced coins which is accepted.

MAXIMUM CHANGE

It is possible to set a limit to the total amount of the change that the coin box will pay when the change return button is pressed or after a single dispensing.

Any credit exceeding the programmed amount with this function will be cashed in.

ACCEPTED COINS

It is possible to define which coins among those recognised by the validator shall be accepted when the coin return tubes are full.

In relation to the coin/value correspondence, the configuration of the coin box needs to be checked

COINS RETURNED

It is possible to define which coins among those available in the tubes shall be used for giving the change. This parameter is only active with coin boxes which do not automatically manage the choice of the tube to be used (Auto changer payout).

In relation to the coin/value correspondence, the configuration of the coin box needs to be checked

ACCEPTED BANKNOTES

It is possible to define which coins among those recognised by the validator shall be accepted.

In relation to the banknote/value correspondence, the configuration of the reader needs to be checked

EXACT CHANGE ACCEPTED COINS

It is possible to define which coins among those recognised by the validator shall be accepted when the machine is in "exact amount" condition.

In relation to the coin/value correspondence, the configuration of the coin box needs to be checked

EXACT CHANGE ACCEPTED BANKNOTES

It is possible to define which coins among those recognised by the validator shall be accepted when the machine is in "exact amount" condition.

In relation to the banknote/value correspondence, the configuration of the reader needs to be checked.

HIDE KEY CREDIT (CASHLESS PRIVATE)

For safeguarding the users privacy this function allows the display of the string "-----" instead of the credit of the cashless system.

RESIDUAL CREDIT

It is possible to decide whether to cash out after a certain time (deleted after) or leave the user with the credit (kept) in excess of the amount for the selection.

CASH-SALE CONTROL

This function allows the recording of the cash transactions as if they were made through a cashless system. The available values are:

- 0 standard operation: the cash transactions are recorded as such
- 1 forced switch to cashless 1: the cash transactions are recorded as transactions performed by the first cashless system
- 2 forced switch to cashless 2: the cash transactions are recorded as transactions performed by the first cashless system

PARALLEL DEVICE

This function allows you to enable the presence of a parallel validator or banknotes reader which is used to recharge the keys.

EXACT CHANGE EQUATION

This allows you to choose among 15 different control algorithms in order to enable the machine to return the change at the end of a selection.

Each algorithm verifies a set of conditions, such as for example the amount of coins in the tubes or the status (empty or full) of the tubes which will be used by the coin box to return the change.

If one of these conditions is not satisfied, the machine will not be capable of giving the change: in this case the display will show the message "No change given"

CASHLESS KEY MAXIMUM CREDIT

This function allows you to set the maximum credit that a key/cashless board can have in order to be accepted by the system. If the key has a greater value, it will be refused.

The value that has been set shall always be greater than or equal to the value set under the function "Revalue Maximum cash"; in case it is modified and is lower, it will automatically be set to the same value of the "Revalue Maximum cash".

CASHLESS KEY MAXIMUM RECHARGE

The function allows you to set the maximum credit that can be charged on a key or board system.

TUBES MINIMUM LEVEL

This allows you to set the number of coins between 0 and 15 for determining the full status of the tubes and the notification to the user "insert exact amount"

BANKNOTE READER FUNCTION (BILL REVALUE)

This function allows you to enable the banknotes reader exclusively for recharging the credit on the cashless system (key or board)

UNDEFINED CREDIT CASH

This function allows you to accept or not the cashless payment systems (key or board) in case the credit of the cashless system is not defined.

USER GROUPS

This function allows you to associate a price list (list 1, list 2 and list 3) to user groups (from 1 to 5). By default, all the user groups are associated to the list

PRICES

This function is active only if the machine has a payment module.

From this menu it is possible to set the prices individually (for each selection) or globally (the same price for all the selections) and define the intervals of the promotional band.

The machine can manage up to 4 different prices for each selection, which can be active depending on the time band that has been set (standard or promotional) and/or on the payment system used.

The prices are grouped in 4 lists and can be programmed (from 0 to 65,535), for each of the 4 lists, both globally with the same price for all the selections and individually for each selection.

The price of each selection can be varied also directly from the keyboard.

In the event that most of the products are sold at the same price it is more convenient to program the price globally and then change the price of the selections which have a different sales price.

BDV, EXECUTIVE, VALIDATORS

With these systems, apart from the standard price list, it is possible to manage a promotional price list if the time band is enabled by means of the appropriate function. The selections will be dispensed at the price of the promotional list in all the set time intervals.

MDB

With these systems it is possible to establish whether to use the 4 price lists at the same time or to use two bands alternatively depending on the time band that has been set.

If the time band is not used, apart from the standard price list it is possible to manage three further price lists depending on the type of cashless support used (key 1-3).

If the time band is used, the selections will be dispensed, for the cashless system, at a price which is different from the standard price; during the time intervals which have been programmed, the selections will be dispensed with two different promotional prices for the standard list and for the cashless system.

PROMOTIONAL TIME BAND

You can program 4 time intervals for different prices retail. Intervals can be set for hours (from 00 Am to 11 Pm) and for minutes (from 00 to 59).

To disable the time band, set the start and end times to 00. The reference time is given by an internal clock which can be adjusted from the configuration menu of the machine (see the "DA Configuration" paragraph).

DOSES

This group of functions allows you to define all the variables which contribute to the preparation of the drink

SELECTION PARAMETERS

By confirming this function, you can access the submenu for managing the parameters; the first option is the choice of the selection which you would like to change. By pressing a key on the keyboard, the corresponding parameters will be displayed, which will be different if the key is a selection or a preselection.

SET COMPOSITION

This group of functions allows you to modify the doses and the parameters in relation to water and powder of the chosen drink.

By confirming this function, the list of ingredients (powder/s and water) of the drink is shown, listed in the order in which the water dose is dispensed (see doses table).

A drink can be composed of a maximum of 4 ingredients (powder/s and water).

Each dose of water can be matched to more than one powder.

The dispensing of water can be controlled through the following parameters:

MIXER

MIXING MODE

It is possible, for each selection, to set the mixing duration of each dose of water which forms the selection.

The duration can be set in two different modes:

- absolute

which means independent of the solenoid valve opening time.

The value of the mixing duration is set in terms of relative volumetric counter pulses (CDV)

- relative

that is, by difference, more or less than the time of closing of the solenoid valve.

E.g.: if the value is 0, the mixing will stop exactly at the same closing time of the solenoid valve.

The duration value of the mixing is always expressed in tenths of a second.

MIXING SPEED (LOW / MEDIUM / HIGH)

The mixing speed can be defined as a function of the desired presentation of the product.

MIXING TIME

It is possible to define, within a single product, for how long the mixer shall be active after the closure of the solenoid valve.

WATER DOSES

The dispensing of water can be controlled through the following parameters:

EVENT START (0 - 3)

The Event start function is used to define the dispensing sequence of the ingredients.

Among the ingredients described in the recipe, the identification number of the first ingredient to be dispensed (start 0) will be indicated as the beginning of dispensing (start) of the next ingredient.

For example, if the “Cappuccino with chocolate” recipe includes:

- Ingredient 1 Milk
- Ingredient 2 Coffee
- Ingredient 3 Chocolate

the dispensing sequence of the ingredients is:

- 1° -Ingredient 1 Milk (start 0)
- 2° -Ingredient 2 Coffee (start 1)
- 3° -Ingredient 3 Chocolate (start 2)

To change the presentation of the drink, placing the milk on top for example, the dispensing sequence of the ingredients could be:

- 1° -Ingredient 3 Chocolate (start 0)
- 2° -Ingredient 2 Coffee (start 3)
- 3° -Ingredient 1 Milk (start 2)

DELAY

It is possible to set (in hundredths of a second) the delay of the water with respect to the previous event.

DOSE IN CC

It is possible to set, directly in cc, the quantity of water desired for each ingredient.

DOSE IN CDV

It is possible to set, directly in cdv (fan pulses), the quantity of water desired for the ingredient.

EXTRACTION PRESSURE

This function is used to adjust the pressure exerted on the pod in the infusion chamber.

Changing this parameter can modify the presentation and quality of the dispensed drink.

This function allows you to choose among the following profiles:

- Low
- Medium
- High

PRE-INFUSION

This function allows you to determine the pre-infusion parameters:

- the quantity of water (in cdv)
- the pre-infusion time (in tenths of a second) before the infusion occurs.

POD SQUEEZING

The squeezing is carried out by the upper piston which, by mechanically compressing the pod, favours the expulsion of the water from the pod before discharging it into the solid waste container.

- ON: squeezing of the pod enabled
- OFF: the pod is not squeezed.

POWDER DOSES

The dispensing of powders can be controlled through the following parameters:

DOSE IN GRAMS

It is possible to set, directly in grams, the desired quantity of powder for each ingredient in the drink.

The function can be used to combine one of the four available doses of ground coffee (low, med1, med2, high) with the selections concerned.

RATE IN G/SEC.

It is possible to set the working speed of the ingredient motors for defining the rate in g/sec.

This value is used for calculating the time required for dispensing the dose in g.

DECAFFEINATED CYCLE OR STEPPED DISPENSING

With this function it is possible to decide, for each selection based on instant coffee in relation to the “global” setting, whether the powder shall be dispensed with the decaffeinated cycle or in steps.

- DECAFFEINATED CYCLE: with this parameter, the powder is dispensed (suggested for instant coffee) before the water, for improving the presentation of the drink:
- IN STEPS: with this parameter the powder is dispensed in steps (which can be set from 1 to 5) at the same time of the water.

DRIP

For each selection it is possible to define the waiting time (programmable from 0 to 2000 hundredths of a second) from the end of dispensing to the closure of the shifting system in order to give the tubes time to empty.

STATUS OF SELECTION

For each selection key it is possible to define whether it shall be enabled or not.

ACCESSORIES

Function not available on the model described in this manual.

COMPLETE SELECTION TEST

With this function it is possible to obtain for each selection, with the door open and without inserting the amount, the dispensing of:

- complete selection
- only water
- only powder

PRODUCT CODE

This function can be used to assign a 16-character (alphanumeric) identification code to each selection for statistical processing.

GLOBAL POWDER DOSES

With this function it is possible to adjust at the same time the powder dose of each ingredient motor related to several selections.

Use the keys **↑** and **↓** to scroll all the powders, press the confirmation key **↵** for setting the grams of chosen powder.

DOSERS SETTING

For the correct conversion of the amounts of the product dose it is possible to set the value of the rate of each of the dosers in g/sec for calculating the grams to be dispensed.

KEYBOARD

KEY <---> SELECTION

With this function it is possible to vary the order of the selections associated with the keyboard defined by the layout that has been set.

The display will show, in a sequence, the list of the foreseen selections and by pressing the destination key, the match is stored.

VERIFICATION NO. OF SELECTION

This allows you to verify the selection number matched to a key.

STOP SELECTION

Enables the “stop delivery” function of a beverage. During delivery of a beverage you can manually stop the delivery by pressing the button corresponding to the required selection again.

WITHOUT SUGAR

With this function it is possible to set all the available selections as “without sugar” by default (ON). Function valid only on some models.

DECAFFEINATED CYCLE

This function acts on the selections based on instant coffee. The selections are identified in the layout as unmodifiable.

By enabling this function in all the selections based on instant coffee (if present) the powder is dispensed before the water

For each selection based on instant coffee it is however possible to change this parameter individually.

DA CONFIGURATION

This group of functions controls all the parameters related to the operation of the machine.



DATE AND TIME SETTING

This function allows you to set the current date and time. This data item is used by the machine for managing the time bands and statistics.

In the absence of power supply the machine maintains the set date and time by means of a buffer battery.

BOILER TEMPERATURE

This function allows you to set the working temperature, in °C, of the boiler.

From this function, press the confirmation key , the temperature value flashes and it can be modified with the keys  and .

DB MANAGEMENT



This group of functions allows you to manage the operational database of the machine

INITIALIZATION

This function shall be used in case of error of the data in the memory or if the software is replaced.

All the statistical data, with the exception of the general electronic counter, will be reset.

When the display is in the "Initialization" function, it is possible to initialize the machine by resetting all the default data.

When the confirmation key  is pressed, the display will show the message "Confirm?". If the confirmation key  is pressed again, some parameters will be requested such as:

- **nation:** meant as a type of basic doses for the various selections
(e.g. IT coffee = 60 cc - FR coffee = 106 cc).
The "nations" provided vary, depending on the model.
- **layout:** for each model and type of doses, there are a certain number of Button-Selection combinations among which it is possible to choose (the combinations for each layout are indicated in the doses-selections table supplied with the machine).
- **tank:** It defines whether the water supply is:
0 - from the mains
1 - from an internal tank

By confirming the options, the message "Execution" is displayed for a few seconds.

SAVE DB CUSTOM

This allows you to save the current configuration of the machine on an external memory; this function is useful in case of customization (for example to the parameters of the selections) as compared to the factory settings.

RESTORE DB CUSTOM

This allows you to restore the customized configuration of the machine which was previously saved with the function "Save modified DB".

In case the factory settings need to be restored, it is necessary to initialize the machine.

DISPLAY

This group of functions controls all the parameters related to the display.

LANGUAGE



It is possible to choose the language, among those foreseen by the software, used for the messages shown on the display.

PROMOTIONAL MESSAGE

ENABLING THE PROMOTIONAL MESSAGE

This function allows you to enable the display of the promotional message which has been set

SETTING THE PROMOTIONAL MESSAGE

The message of 5 rows of 16 characters can be composed by using the keys  and  for scrolling the available characters.

By pressing the confirmation key  the first character that can be modified flashes.

The message is stored by pressing the key .

PROMOTIONAL IMAGE

This allows you to enable/disable the promotional image shown on the display in normal user mode:

- ON: in normal user mode the message "Select drink" is alternated, every 3 seconds, with the promotional image
- OFF: in normal user mode, only the message "Select drink" is shown

CONTRAST SETTING

This function allows you to adjust the contrast of the display from a minimum of 5% to a maximum of 99% (default).

COLOUR OF STANDBY LIGHTS

This function allows you to choose whether to leave the keyboard lights:

- OFF
- ON, choosing the colour among the preset ones, when the machine is on standby.

CURRENCY SYMBOL

This function is active only if the machine has a payment module.

It allows you to enable, when the credit is displayed, the symbol of the currency that has been set (€, \$, or £)

USER DISPLAY

With this feature it is possible to enable and choose which kind of information you want to see on your display during normal operation.

Information you can see are:

- Time
- Cellar temperature of "slave" machine

MENU MANAGEMENT

PASSWORD

This is a 5-digit numerical code which is requested for displaying all the functions of the menu.

By default, the value of this code is set to 00000

From this group of functions it is possible to enable and set the password.

ENABLING THE LOADER MENU

With this function it is possible to make visible or not the loader first level menu.

Using the keys **↑** and **↓**, you can scroll through the items of the first-level loader menu; the key **↵** can be used to modify the status of the chosen menu (ON/OFF).

STANDBY DIRECT KEYS

The function allows you to enable 3 of the 6 keys located inside the door.

Each enabled key can be associated to a direct function. (see direct keys functions)

DIRECT KEYS FUNCTIONS

This function allows you to associate the following functions with the keys located inside the door:

- OFF (no function associated with the chosen key)
- Faults reset
- Mixer wash
- Infuser unit wash
- Display number of strokes
- EVADTS connection
- Loading the tubes of a coin mech
- Unloading the tubes of a coin mech

ESPRESSO UNIT

PRE-GRINDING

This function allows you to enable or disable the grinding of the coffee dose for the subsequent selection. This allows you to reduce the preparation time of a ground coffee-based selection.

By default, this function is disabled.

ESPRESSO BOOST

By enabling this function it is possible to heat the hydraulic circuit and the espresso unit before an infusion of espresso.

In the event that no coffee-based selections are made for a long time, a small quantity of warm water is dispensed before the release of the coffee dose.

COFFEE WASTE

This function allows you to set the number of selections of "espresso" and "fresh brew" after which the machine displays the request to empty the residue container.

RESET OF COFFEE WASTE COUNTER AT START-UP

This function allows you to enable the request to reset the coffee waste counters when the machine is started. Press the key **↵** to reset or **↶** to cancel the resetting.

FIRST COFFEE HEATING TIME

In the event no espresso-based selections are made for a long time, the heating of the boiler is enabled for 9 seconds before performing an infusion of espresso.

GRINDER SHUTDOWN

A sensor detects the effective rotation of the grinder during the grinding time.

In the event of a blockage (due to foreign bodies, etc.) the grinder is shutdown and the espresso-based selections are disabled.

This option can be used to enable/disable the check of the grinder rotation.

ESPRESSO UNIT POSITION

With this function you can set the position of the group while the dose of ground coffee is being delivered.

The regulation occurs through the Keys **↑** and **↓**

WASH

AUTOMATIC MIXER WASH

It is possible to set the time for the automatic wash of the mixers installed.

By setting the time to 24:00, the function is disabled (default setting).

AUTOMATIC UNIT WASH

This function allows you to set the daily automatic wash (rotation and dispensing of water) of the espresso unit by setting the time when to perform the wash.

By setting the time to 24:00, the function is disabled (default setting).

INSTANT DRINKS BOOST

This enables the function for heating the hydraulic circuit and mixers before the preparation of an instant powder-based drink.

The heating (dispensing of a small amount of hot water) occurs if no dispensing has been performed in the mixers during the last 3 minutes.

MIXER COOLING

If the machine is equipped with a cold unit, the function is enabled.

If no dispensing was made within the last 3 minutes in the mixers of the cold drinks, a small quantity of cold water is dispensed before the syrup-based selections.

WASH PASSWORD

From this group of functions it is possible to set the

- Mixer wash password

Password to be entered in normal operation (with door closed) to wash the mixer.

The keyboard takes on the respective numerical values shown in the figure at the beginning of this chapter.

- Unit wash password

Password to be entered in normal operation (with door closed) to wash the espresso unit.

The keyboard takes on the respective numerical values shown in the figure at the beginning of this chapter.

MIXER AND ESPRESSO UNIT WASH

Enables/disables the washing of the mixers and espresso unit.

ACCESSORIES

TANK

This function allows you to define whether the machine water supply is through the mains or internal tanks:

- 0: water supply from the mains;
- 1: internal tank;

PHOTOCELL

On the models equipped with “cup sensor” (photo cell) which detects the presence of an object in the dispensing unit.

With the function enabled, if an object is detected in the dispensing unit, the dispensing of the drink is started.

If the cup remains in the dispensing unit, then the message “remove the cup” will be shown when the next selection request is made.

The lamp of the dispensing unit is controlled by the cup sensor.

The dispensing unit lighting operation mode can be set as follows:

- 0: lighting always active
- ON: defining the on time of the lighting (in hundredths of a second) from the beginning of the drink preparation.

JUG FACILITIES

This function allows you to set the number of consecutive dispensing events of a selection for filling a jug.

The number of dispensing events can be programmed from 1 to 9, and the default value is 5

WASTE RESET PASSWORD

The function allows you to set the password (to be entered with the door closed) to reset the counter which manages the coffee waste container.

With the password set to 00000, the password is not active.

“FREE-VEND” PASSWORD

The function allows you to set the password (to be entered with the door closed) to enable the free of charge dispensing of the drinks (free vend).

With the password set to 00000, the password is not active.

“JUG FACILITY” PASSWORD

The function allows you to set the password (to be entered with the door closed) to enable the consecutive dispensing of a selection for filling a jug.

With the password set to 00000, the password is not active.

HOT WATER SELECTION COUNTING

Enables/disables the counting of the hot water dispensing events from the stroke counter

KEYBOARD LOCK PASSWORD

This function allows you to set the password (to be entered with the door closed) for enabling/disabling the selection keyboard lock.

When the keys are locked, the message "Service suspended" appears on the display.

With the password set to 00000, the password is not active.

CUP ADJUSTMENT TIME

Function not available for this model.

ENERGY SAVING

In order to save energy when the machine is not used, it is possible to choose among the following energy saving options:

ENERGY SAVING:

With this option it is possible, in the time intervals which are set with the function "Energy Saving Parameters", to suspend the service of the vending machine and switch off or not the boiler.

The selections are not available for the whole duration of the Energy Saving period.

- **Sleep mode:** with this option, after 15 minutes of inactivity of the vending machine, the LEDs of the door switch off and the temperature of the boiler decreases to approx. 70 °C. When any selection button is pressed, the machine restarts the normal operations and as soon as the operational temperature is reached, the selections become available again.
- **Light off only:** with this option it is possible to switch off the lighting LEDs of the keyboard during the time intervals set by the function "Energy Saving Parameters" while the boiler continues to work normally. When any selection button is pressed, the lighting of the keyboard is reactivated and the machine immediately restarts the normal operations.

ENERGY SAVING PARAMETERS

With this function it is possible to set up to 4 time bands during which the energy saving profiles will switch on (Energy Saving and Soft Energy Saving).

To disable the time band, set the start and end times to 24.00.

ENERGY SAVING PASSWORD

This function sets the password (to be entered with the door closed) for restoring the machine's operation when the "energy saving" mode is on.

Entering the energy saving password when the machine is in normal user operation causes the machine to go into energy saving mode.

With the password set to 00000, the password is not active.

LED D.A. OUT OF SERVICE

It is possible to define whether the lighting LEDs shall be switched on or not (red) when the machine is out of service and the "Energy saving" mode is on .

SET DISPENSING MAINTENANCE

With this function it is possible to establish how many dispensing tests can be made at each door opening. By default, the value is set to 0 and there are no limitations on the dispensing tests.

COLD UNIT ID SETTING

This function is active if the cold unit is present.

It allows you to assign an identification number to the cold unit (from 0 to 9) connected to the machine.

If there are several machines connected in series, the ID numbers of the cooling unit shall be different.

MASTER SLAVE

The machine control system is arranged for the connection in series with other vending machines.

SETTINGS

This function allows you to set the hierarchies of the master / slave1 / slave2 relationships between the connected machines.

This machine can be configured as "Master", therefore assuming control of the second machine or as "Slave", therefore leaving the control to the other machine.

Furthermore, the numbers of the selections will be set, with two digits (XX) or three digits (0XX; 9XX)

By default, the master/slave function is not enabled.

SLAVE PRICE HOLDING

In case the Executive payment system is set in "Price Holding" mode, with this function it is possible to set the same mode also in the software of the slave machine.

RETURN VIRTUAL PRICE

If the payment system is set with BDV and/or Executive protocol and for combined or virtual selections (whose relative menus are on the slave machines), with this option it is possible to establish whether to keep (OFF) or not (ON) the partial amount, in case the second selection/dispensing should fail.

RESET MINISLAVE

With this function it is possible to reset all the settings related to the master/slave function on the slave machine.

MONITOR SLAVE

With this function it is possible to scroll all the information related to a possibly connected slave machine. By switching on the “slave” machine with the display on this function, the display will show in sequence the information of the slave related to:

- Software Version
- Type of slave (XX, 0XX, 9XX)
- Presence of the photocells for dispensing detection
- Number of trays and drawers
- Presence of a device blocking the opening of the collection area
- Temperature detected by the internal probe.

To exit the function it is necessary to switch off the “master” machine.

DISPLAY SLAVE INFORMATION

With this function it is possible to display the instant temperature of the possibly connected “slave” machine.

DA SERIAL NUMBER

With this function it is possible to vary the eight-digit numerical code which identifies the machine (00000000 as default).

PROGRAMMING OF THE OPERATOR CODE

With the “Operator code” function it is possible to vary the six-digit numerical code which identifies groups of machines (000000 as default).

INSTALLATION DATE

With this function the current date of the system is set as installation date.

The date is printed when the statistics are extracted.

MANAGEMENT OF THE EXTRACTOR

This function allows you to enable the continuous operation of the steam extractor fan during preparation of the drinks which use instant powders.

- ON extractor fan in continuous operation
- OFF extractor fan in operation only during the preparation of the drink and for the 30 subsequent seconds.

MAXIMUM NUMBER OF COUNTERS

With this function it is possible to set the maximum number of selections to be reached for blocking the machine. It is possible to set the counters for the selections:

- Espresso
- Instant drinks
- Espresso + instant drinks

By setting the counter to a new value, the previous count is cancelled.

This function is active if the password to reset the counters has previously been set.

PASSWORD TO RESET THE COUNTERS

This function allows you to set the password to be inputted in normal user mode (with the door closed) for resetting the counters of the selections.



If the password is set to zero, this function is not active.

ALERTS

This function allows you to manage the counters of the alerts “product running out”.

ALERTS THRESHOLDS

This function allows you to set the “product running out” alert thresholds.

Use the keys  and  to scroll through the products, and the key  to change the value.

RESETTING ALERTS COUNTERS

This function allows you to reset the counters which manage the “product running out” alert thresholds.

TEST

This group of functions allows you to perform tests on the main components of the machine.

DISPENSING TESTS

This function allows you to obtain for each selection, with the door open, the dispensing of:

- complete selection
- only water
- only powder
- selection without accessories (test dispensing not available for this model)
- accessories only (test dispensing not available for this model)

SPECIAL FUNCTIONS

This group of functions allows you to:

- operate the infuser unit
- release a coffee dose
From the function you can set the time-dosed quantity of ground coffee.
The time-dosed quantity is expressed as a percentage of the grinding time of the volumetric quantity
- open a solenoid valve for allowing air to enter in the event the boiler is emptied for maintenance
- perform manual installation of the boiler (filling the hydraulic circuit)
- move the espresso unit
- move the espresso unit while the piston is pressing down
- wash the infuser unit.

SELF-TEST

This function allows you to verify, in semi-automatic mode, the operation of the main components of the machine. By pressing the confirmation key, the flashing message "SELF TEST" will be displayed.

It is possible to abandon each operation and go to the next one by pressing the exit key; instead, by confirming with the confirmation key, the self test cycle starts. Some of the controls are automatic, while others require the controlled component to be manually operated.

In sequence:

- Activation of ingredient motors for 2 seconds
- Activation of mixer motors for 2 seconds at different speeds
- Rotation of the infuser unit
- Control of the washing button
- Full waste; the machine remains in standby until the full waste microswitch is operated manually
- Door lighting test; check that the keyboard lighting is working
- Switch on the dispensing unit lighting (if present)
- Keyboard check; the machine displays the number of the button that shall be pushed and it indicates the latter also by switching on the corresponding LED and it remains in standby for the actuation before switching to the next key
- Check that the boiler temperature probe is working
- Checking that the buzzer is working
- Checking that the coin box (if present) is working
- Extractor management; the machine turns the steam extractor fan on and off during the preparation of instant drinks.
- Display check; the machine turns on all the points of the display to allow the visual operation check.

STATISTICS

The data related to the operation of the machine are stored both in total counters and in relative counters, which can be reset without losing the total data.

ELECTRONIC COUNTER

An electronic counter memorizes in an aggregate mode all the items dispensed from the last reset.

DISPLAY ELECTRONIC COUNTER

Displays the number of items dispensed since the last reset.

RESET ELECTRONIC COUNTER

Resets the electronic counter.

DISPLAY NUMBER OF STROKES AT START-UP

Enables the display of the total number of items dispensed since the last reset, during the machine start-up phase.

EVA DTS

EVA DTS communication protocol (European Vending Associations Data Transfer System) foresees two codes for identifying the machine and recognising the data transfer terminal:

COMMUNICATION PROTOCOL

From this function it is possible to decide which communication protocol to use for the communication with the data acquisition device.

The available communication protocols are:

DDCMP ENHANCED

with the following configurable parameters:

- **Pass code:** this is a four-character alphanumeric code (0-9; A-F) which must be equal to the one of the data transfer terminal for permitting its identification.
Default settings: 0000
- **Security code:** this is an alphanumeric code for mutual recognition between machine and EVA DTS terminal.
Default settings: 0000
- **End of transmission:** if enabled, it is capable of recognising the end of transmission signal which is sent with the last packet and of interrupting the data transmission.

DEX/UCS

for this protocol there are no configurable parameters:

DATA TRANSMISSION

This function allows you to select which communication interface to use for data transmission. The available interfaces are:

- "RS232" and "IrDA": for the communication with serial or infrared data acquisition devices.
- "ALWAYS EVA DTS" for communications with data acquisition and transmission devices (telemetry).

EVADTS TYPE

This function allows you to select the mode in which to manage the speed of communication with the data acquisition devices:

- "ENHANCED", the communication speed is automatically adjusted to the maximum speed of the slowest device.
- "FIXED", the communication speed is fixed to the speed set with the Baudrate function

BAUDRATE (TRANSMISSION SPEED)

This allows you to choose the communication speed of transmissions (only if "EVA DTS type" is set with "fixed").
Default setting: 2400bps.

CONNECTION

By activating this function, the machine waits for the connection with a data acquisition device EVA DTS.

ERASING DATA

The statistics can be reset, for the relative counters, in a global mode (all types of data) or in a selective mode, for:

- selections
- discounts-overpays
- faults
- coin box data
- By pressing the confirmation key **↵** the flashing confirmation request "Confirm?" is displayed.

By pressing the confirmation key **↵** the message "Execution" is displayed for a few seconds and the statistics are reset.

DISPLAY OF GENERAL STATISTICS

By pressing the confirmation key  the stored data is displayed in sequence:

- 1 - single selection counter;
- 2 - bands counter;
- 3 - discounts counter;
- 4 - faults counter;
- 5 - coin box data.

RESETTING OF GENERAL STATISTICS

The statistics can be reset, for the relative counters, in a global mode (all types of data) or in a selective mode, for:

- selections
- discounts-overpays
- faults
- coin box data
- By pressing the confirmation key  the flashing confirmation request "Confirm?" is displayed.

By pressing the confirmation key  the message "Execution" is displayed for a few seconds and the statistics are reset.

DISPLAY OF RELATIVE STATISTICS

By pressing the confirmation key  the stored data is displayed in sequence:

- 1 - single selection counter;
- 2 - bands counter;
- 3 - discounts counter;
- 4 - faults counter;
- 5 - coin box data.

RESETTING THE RELATIVE STATISTICS

The statistics can be reset, for the relative counters, in a global mode (all types of data) or in a selective mode, for:

- selections
- discounts-overpays
- faults
- coin box data

By pressing the confirmation key  the flashing confirmation request "Confirm?" is displayed.

By pressing the confirmation key  the message "Execution" is displayed for a few seconds and the statistics are reset.

BDV AUDIT PROTOCOL

The data related to the coin box are the indication in real value of:

- Aud.1 Money in tubes
Money in the coin tubes at that point in time
- Aud.2 Money to tubes
Money sent to coin mech tubes
- Aud 3 Money to the counter
Money sent to coin till
- Aud 4 Change return
Total amount of returned change
- Aud 5 Dispensed money
Total amount of manually dispensed money
- Aud 6 Surplus
Money surplus. Amounts overpaid by the client, which have not been returned (in the event that there is no availability of money for the change)
- Aud 7 Total retails
Total value of retails
- Aud 8 Correct change
Values of retails done in a "no change" condition
- Aud 9 Mixed dispensing
Total value of the dispensed items which were paid for in a different way, for example also through other types of payment (C.P.C., token)
- Aud 10 Coin payment
Amount of money inserted in the coin slit through the "Coin payment" function.

MDB AUDIT PROTOCOL



- Aud.1 Money in tubes
money in the coin tubes at that point in time
- Aud.2 Money to tubes
Money sent to coin mech tubes
- Aud 3 Money to the counter
Money sent to coin till
- Aud 4 Change return
Total amount of returned change
- Aud 5 Surplus
Money surplus. Amounts overpaid by the client, which have not been returned (in the event that there is no availability of money for the change)
- Aud 6 Tubes distribution
Value of the coins returned in the “tubes management” function
- Aud 7 Tubes payment
Value of the coins cashed in the manual loading function.
- Aud 8 Cash retails
Value of total sales made in cash (coins + bills)
- Aud 9 Collected bills
Value of collected bills
- Aud 10 Key reload
Amount of money loaded on a key
- Aud 11 Key retails
Amount of money cashed through key retails
- Aud 12 Manually dispensed money
Value of the coins dispensed manually through the distribution button on the coin box.

PRINT STATISTICS

By connecting an RS232 serial printer with a baud rate of 9600, 8 data bits, parity of None and 1 stop bit to the serial connector on the button board, it's possible to print all the statistics described in the paragraphs “display general statistics” and “display relative statistics”; the printout also shows the code of the machine, the date and the software version.

Printing the statistics can be performed in a relative or total mode.

To connect the printer follow these steps:

- press the printing confirmation key  and the confirmation request “Confirm?” is displayed;
- connect the printer before confirming;
- by pressing the confirmation key  printing will start.

COMMUNICATION

This menu contains the communication functions of the machine.

UP-KEY

SETUP MANAGEMENT

UPKEY -> DISPENSER

This function, after having inserted the upkey in the appropriate slot on the CPU board, allows you to select the setup file of the list which will appear on the display; if you then press the confirmation key, the chosen setup file will be loaded into the machine.

DISPENSER ->UPKEY

This function, after having inserted the upkey in the appropriate slot on the CPU board, allows you to save on the Upkey a setup file with the configuration present at that point in time on the machine.

You must specify the name you would like to give the file (e.g.: KREA0000.STP)

DELETE

With this function it is possible to delete the setup files one by one from the inserted Upkey

DELETE ALL

With this function it is possible to delete all the setup files from the inserted Upkey.

UPKEY STATISTICS MANAGEMENT

DISPENSER ->UPKEY

By confirming this function after having inserted the Upkey in the appropriate slot on the CPU board, you can save a statistics file on the Upkey with all the statistical data which are stored in the machine, specifying the name you would like to give the file (e.g.: KREA0000.EVA)

DELETE

With this function it is possible to delete one by one the statistics files from the upkey

DELETE ALL

With this function it is possible to delete all the statistics files from the inserted Upkey

FAULTS

The machine has a number of sensors for keeping the various functional groups under control.

When an anomaly is detected, the display of the machine will show the type of fault and the machine (or part of it) is put out of service.

The detected faults are memorized in appropriate counters; the faults managed by the software can be in relation to functional groups which are not present on the specific model; they are however listed when the menu is scrolled.

READING EXISTING FAULTS

With this function it is possible to display the existing faults

Press the confirmation key  to display the existing faults.

If there are no existing faults, by pressing the confirmation key  the message "End of faults" will be displayed. The following faults are controlled:

EMPTY WATER

If the air-break microswitch remains closed for one minute, the water inlet solenoid valve remains excited waiting for water to return.

If the internal tank water supply system is installed in the machine, the pump will switch off.

FULL WASTE

The espresso-based selections are disabled when the number of used pods set in the menu is reached .

The solid waste container can contain up to a maximum of 150 used pods.

AIR-BREAK

The machine will stop working if, after 10 selections, the microswitch has never notified the lack of water

EMPTY CUP

This fault, even though present in the faults list, is not managed on the model described in this manual

CUP SHIFTING SYSTEM

This fault, even though present in the faults list, is not managed on the model described in this manual

VOLUMETRIC COUNTER (FAN)

No counting of the volumetric counter (fan) within a maximum time.

MACHINE BOARD

Lack of communication between CPU board and machine board.

COIN BOX

The machine will stop working if it receives a pulse longer than 2 sec. on a validator line or if the communication with the serial coin box does not occur for longer than 30 (Executive protocol) or 75 (BDV protocol) seconds.

COFFEE RELEASE

If after releasing the dose of ground coffee the microswitch of the doser detects presence of coffee in the doser chamber, the coffee-based selections are disabled.

INFUSER UNIT -MICROSWITCH UNIT FAULT-

All the faults related to the infuser unit are controlled by a "unit position" control microswitch.

The control microswitch is activated by the infuser unit gear motor cam.

This fault indicates that during handling of the infuser unit, the control micro is not operated within a certain time limit.

It is possible that this fault is combined with another positioning fault of the infuser unit

INFUSER UNIT -START UNIT FAULT-

The gear motor is not capable of bringing the infuser unit from the idle position to the infusion position.

INFUSER UNIT -INFUSER UNIT FAULT-

The control microswitch indicates that the infuser unit is not in the infusion position

INFUSER UNIT -DISPENSING UNIT FAULT-

During the infusion phase, the control microswitch indicates the movement of the espresso unit.

INFUSER UNIT -DISCHARGE UNIT FAULT-

At the end of the infusion the control microswitch indicates that the infuser unit is not in the "used pod discharge" position.

INFUSER UNIT -IDLE UNIT FAULT-

The control microswitch indicates that the infuser unit did not go back to the idle position at the end of the discharge of the pod.

EMPTY COFFEE

If the ground coffee dose is not achieved within 15 seconds after activation of the grinder, the coffee-based selections are disabled.

GRINDER SHUTDOWN

If the grinder fails to rotate or rotates too slowly, the espresso-based selections are disabled while the instant coffee-based selections remain available.

RAM DATA

One or more areas of the RAM memory contain altered data which was corrected with the default values.

The machine continues to work, but it is preferable to proceed with the initialization as soon as possible.

ESPRESSO BOILER

The machine will stop working if after 10 minutes of heating from start-up or from last selection the water in the boiler has not reached the temperature.

CUP RELEASE

This fault, even though present in the faults list, is not managed on the model described in this manual

FAULTY DOSER (DOSER 1 - 9 FAULT)

If the current absorption of an ingredient motor is not between the range of default values, all the selections in which the doser is involved are disabled.

FAULTY MIXER (WHIPPER 1 - 6 FAULT)

If the current absorption of a mixer motor is not between the range of default values, all the selections in which that mixer is involved are disabled.

SHORT CIRCUIT MOSFET

If a control device for the DC motors on the activations board (mosfet) remains active, the machine will signal a fault.

SHORT CIRCUIT

If the software detects a short circuit in one of the DC motors connected to the activations board, this fault will be displayed. It is possible that at the same time of this, a fault is also detected on one of the DC motors.

SUGAR/STIRRERS FAULT

This fault, even though present in the faults list, is not managed on the model described in this manual

WATER FAULT

The water fault is declared during the standby mode of the D.A. if the water inlet solenoid valve is activated for a total time longer than 20 sec.

If there is a water fault it is possible to manually restore the service by pressing a key on the control panel. The water inlet solenoid valve is powered for a maximum time of 20 sec.; if the level is not reached the solenoid valve closes and the water fault is signalled again.

It is necessary to wait 30 minutes before performing 2 further restore attempts.

At the 4th attempt, the solenoid valve is disabled permanently (at this point it is necessary to switch off/on the d.a. for obtaining 3 further attempts or resetting the fault from the programming menu).

FAULTS RESET

By confirming this function all the faults are reset.

FAULTS HISTORY

It is possible to display the last 16 faults, from the most recent one to the oldest one, scrolling with the keys **↑** and **↓**; the corresponding date and time of intervention are also displayed and whether the fault is still active or not (ON / OFF), similar to the data contained in the data audit EVA DTS.

RESETTING THE FAULTS HISTORY

By confirming the function, all the faults present in the faults history are reset.

WASTE RESET PASSWORD

Sets the password to be entered for resetting the counter that manages the solid residues.

Chapter 3 Maintenance

The integrity of the machine and compliance of the corresponding systems with the regulations shall be verified, at least once a year, by qualified personnel.

Always switch off the machine before starting maintenance operations which require the disassembling of components.

The operations described below shall be carried out only by personnel with specific knowledge of the operation of the machine both from the point of view of electrical safety and of hygiene.

GENERALITIES

In order to ensure its correct operation, the machine shall be subject to periodical maintenance.

Listed below are the operations to be carried out and the related expiry dates; they are, obviously, indicative because they depend on the conditions of use (i.e. water hardness, environment humidity and temperature, type of product used, etc.).

The operations described in this chapter do not include all the maintenance interventions.

More complex interventions (i.e. descaling of the boiler) shall be carried out by an engineer with specific knowledge of the vending machine.

In order to avoid risks of oxidation or of chemical aggressions in general, the painted surfaces and the surfaces in stainless steel need to be kept cleaned by using neutral detergents (avoid solvents).

Jets of water are to be absolutely avoided for washing the machine.

DOOR SWITCH

When the door is opened, a microswitch removes the voltage from the electrical system of the machine. When the door is open, voltage is given to the machine by inserting the appropriate key.

With the door open, there is no access to live-parts. Inside the machine, only those parts which are protected by covers and which are highlighted with a label "disconnect voltage before removing the cover" remain live.

Before removing these covers it is necessary to disconnect the power supply cable from the mains.

The door can be closed only after removing the key from the door switch, lowering the upper panel of the machine and closing the opening of the coffee container so that the closure control devices are enabled.

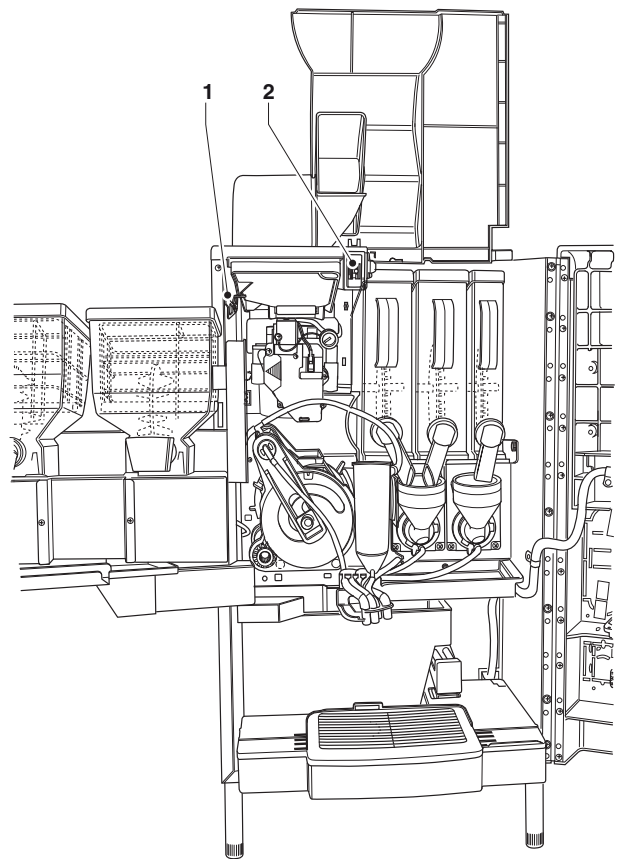

Fig. 23

- 1- Upper panel closure control device
- 2- Door switch

ESPRESSO UNIT MAINTENANCE

Every 10,000 dispensed items or, however, every 6 months, a small maintenance intervention on the infuser unit is required for optimising its operation.

For performing the maintenance operations it is necessary to remove the unit by following these steps:

- Disconnect the espresso coffee outlet nozzle from the unit by rotating it by 90° from the rod and pulling it outside.
- Disconnect the fresh brew coffee outlet nozzle from the unit by rotating it by 90° and pulling it outside.
- Act the unit end stop lever rotating it until the horizontal position.
- Pull out the infuser unit.

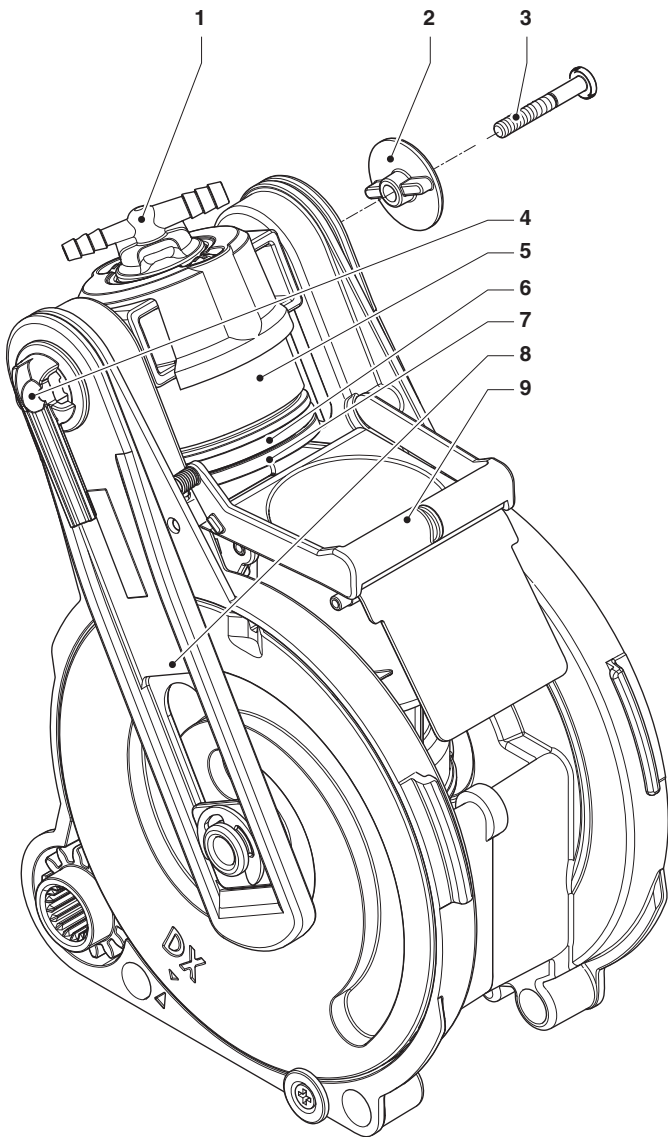

Fig. 24

- 1- Fresh brew nozzle
- 2- Key
- 3- Side screw
- 4- Espresso nozzle
- 5- Upper piston
- 6- Upper piston seal
- 7- Upper filter
- 8- Rod
- 9- Lower scraper

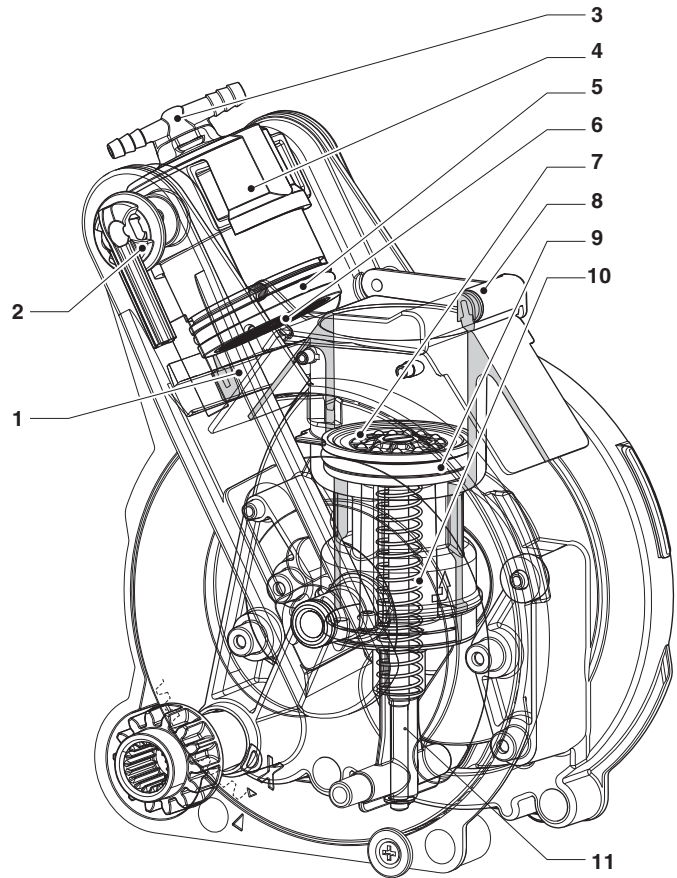

Fig. 25

- 1- Upper scraper
- 2- Espresso nozzle
- 3- Fresh brew nozzle
- 4- Upper piston
- 5- Upper piston seal
- 6- Upper filter
- 7- Lower filter
- 8- Lower scraper
- 9- Lower piston seal
- 10- Lower piston spring
- 11- Piston stem

DISASSEMBLY/REPLACEMENT OF THE FILTER AND UPPER SEAL

In order to disassemble or replace the filter and the upper seal, follow these steps:

- Unscrew the side screw intended to fasten the key
- Rotate the upper piston upwards.
- Remove and replace the upper seal.
- Unscrew the fixing nut to remove the upper filter
Reposition the filter support making sure that the flat surface is facing upwards.

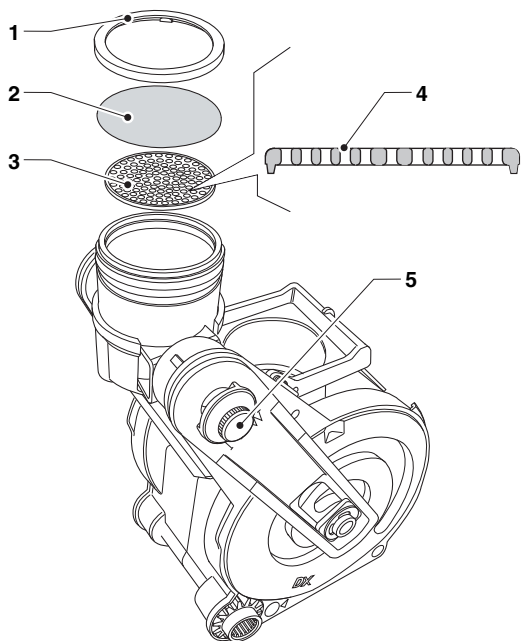

Fig. 26

- 1- Fixing nut
- 2- Upper piston filter
- 3- Upper piston filter support
- 4- Filter support correct positioning
- 5- Saw tooth screw for fixing the key

DISASSEMBLY/REPLACEMENT OF THE FILTER AND LOWER SEAL

In order to disassemble or replace the filter and the lower seal, follow these steps:

- Manually bring the unit to the discharge position with the lower piston in high position.
- Unscrew the central fixing screw for removing the filter.
- Press on the end of the piston stem guide for obtaining an extra run of the lower piston.
- Pull with a small screwdriver for sliding the lower piston out from the piston stem being careful not to damage the piston or the sealing elements
- Remove and replace the lower seal.

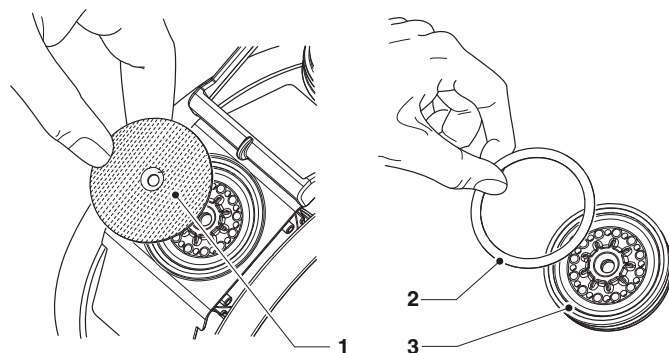

Fig. 27

PERIODICAL OPERATIONS

This manual shows the potential weak points and includes information about controlling the possible growth of bacteria.

Under the current health and safety regulations, the operator of the machine must apply the self-control procedures, identified in accordance with Directive HACCP (Hazard Analysis Critical Control Point) and national legislation.

At least every year, or more frequently depending on the use of the machine and the quality of the water used, it is necessary to clean and sterilise the entire circuit and the parts which are in contact with the food products.

STERILISATION

- all the components which are in contact with the food products, including the tubes, shall be removed from the machine and disassembled in all their parts;
- all the residues and visible films shall be mechanically removed using brushes if necessary;
- the components shall be kept into a sterilising solution for at least 20 minutes;
- the internal surfaces of the machine need to be cleaned with the same sterilising solution;
- rinse well and reassemble the components.

Before restarting the machine, the sterilising operations need to be carried out again with the components installed, as described in the chapter "Sterilisation of the mixers and of the food products circuits"

CONDUITS AND MIXERS

Periodically, apart from the external parts of the mixers which need to be cleaned of any powder residue, particularly in the funnel area, the parts of the mixer which are in contact with the drink should also be sterilised.

Absolutely do not use jets of water for cleaning.

The parts that need to be cleaned are:

- Powder funnels, expansion nozzle, mixers and instant drinks dispensing pipes;
- Pipes and dispensing nozzles;
- Dispensing unit.

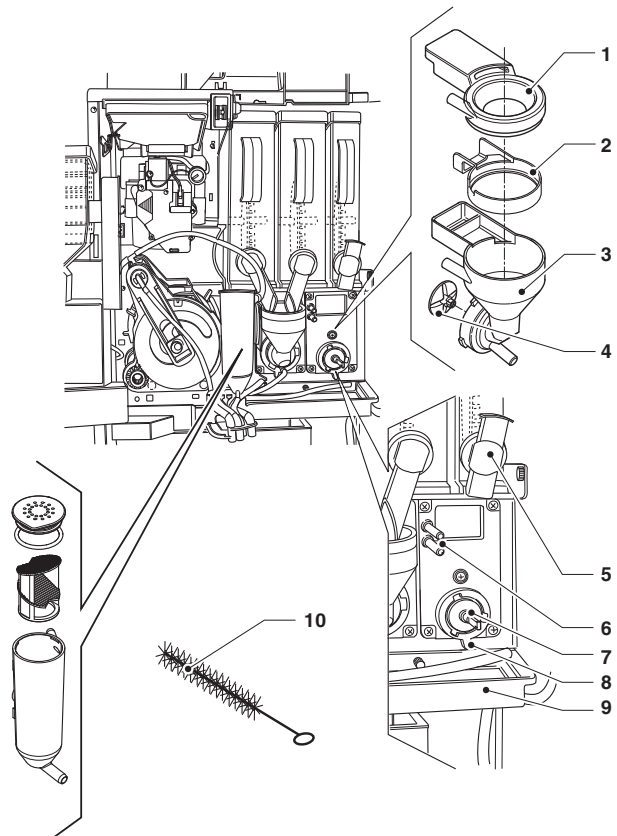

Fig. 28

- 1- Powder funnel
- 2- Splashguard ring
- 3- Water conveyor
- 4- Mixer fan
- 5- Powder nozzle
- 6- Water inlet nozzle
- 7- Stuffing box seal
- 8- Mixer fixing flange
- 9- Drops collection container
- 10- Tube cleaning brush

Open the cover of the mixer dispensing cell and lift the powder nozzles up to the end stop.

- Remove the powder funnels, the water conveyors, the powder deposit funnels and the mixer motor fans from the mixers;
- the fans can be removed by simply pulling gently to free them;

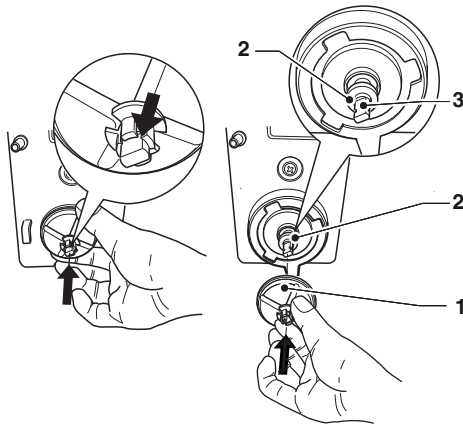

Fig. 29

- 1- Fan
- 2- Stuffing box seal
- 3- Shaft discharge

- Verify that the stuffing box lip seal is not broken and has not lost elasticity; for inserting it, place the seal just beyond the shaft discharge. By inserting the fan completely, the stuffing box seal will assume the correct position.

- Wash all the components with sterilising products (follow the dosage indicated by the manufacturer), being careful to mechanically remove the visible residues using brushes if necessary.

The sterilisation is performed by means of sterilising products.

- Dip the parts for approx. 20 minutes in a recipient containing the previously prepared sterilising solution.
- Reinstall the conveyors and the water funnels.
- Reinstall the powder deposit drawers and the powder funnels after having carefully rinsed and dried them.
- When reassembling the fans make sure to insert them completely until they click.

After installing the components it is however necessary:

- To wash the mixer and add a few drops of the sterilising solution into the various funnels.
- Once the sterilisation has been performed, rinse the components well in order to remove any possible residue of the solution used.

PRODUCTS CONTAINERS

- Remove the containers from the machine;
- Remove the product outlet nozzles and take the augers off from the back of the container;
- Clean all the components with a solution of hot water and sterilising products and dry them carefully.

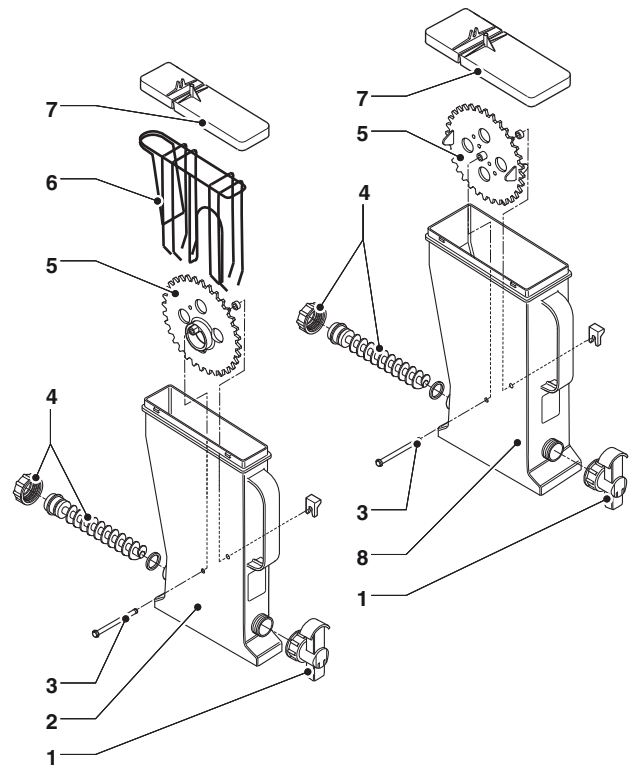

Fig. 30

- 1- Powder nozzle
- 2- Container
- 3- Pin for wheel
- 4- Auger
- 5- Sprocket
- 6- Scraper (if present)
- 7- Container covers
- 8- Container

BOILER MAINTENANCE

Depending on the mains water hardness and on the number of selections made, a descaling of the boiler could be required.

This operation needs to be carried out exclusively by qualified technical personnel.

For descaling the boiler, it is necessary to remove the boiler from the machine.

For descaling only use non-toxic and non-aggressive biodegradable products.

Rinse well before reassembling the components.

When reassembling, make sure that:

- the electrical connections (terminals, faston, etc...) are perfectly dry and well connected
- the safety thermostats are correctly positioned and connected
- the hydraulic connections are correct.

ESPRESSO BOILER THERMAL PROTECTION

In case of intervention of the thermal protection the cause of failure should be identified and eliminated.

The thermostat must be reset manually through the button placed on the thermostat itself.

The espresso boiler has a touch safety thermostat, which deactivates the boiler resistance in case the temperature in the boiler exceeds the safety temperature (125°C).

In case of intervention of the thermostat, the system must be restored manually with the button placed on the thermostat, after verifying and eliminating the cause of the fault.

Important!

In case of intervention of one of the safety thermostats, the boiler temperature probe will be damaged and it will be necessary to replace it.

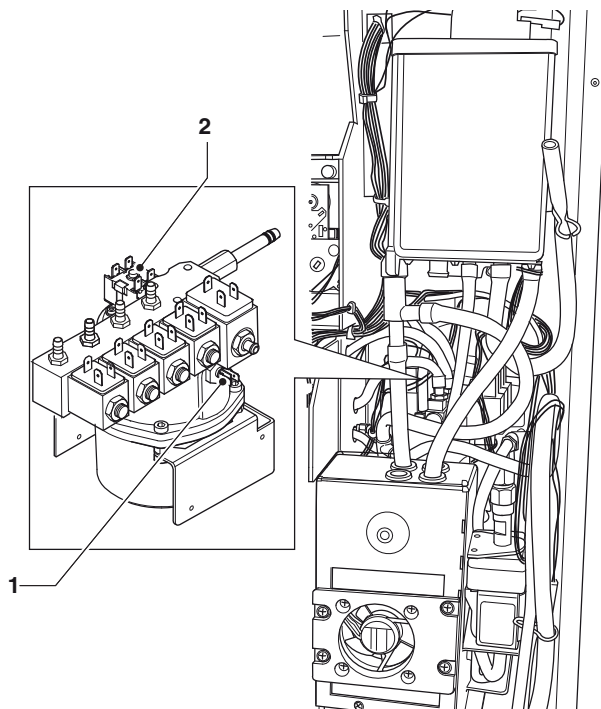

Fig. 31

- 1- Temperature probe
- 2- Safety thermostat

BOARDS FUNCTION

CONFIGURATION OF ELECTRONIC BOARDS

The electronic boards are designed to be used on several models of machines.

In case of replacement, or in order to change the performance of the machine, it will be necessary to verify the configuration of the boards and load the adequate software.

The boards can be accessed by removing the back of the machine or the cover of the door.

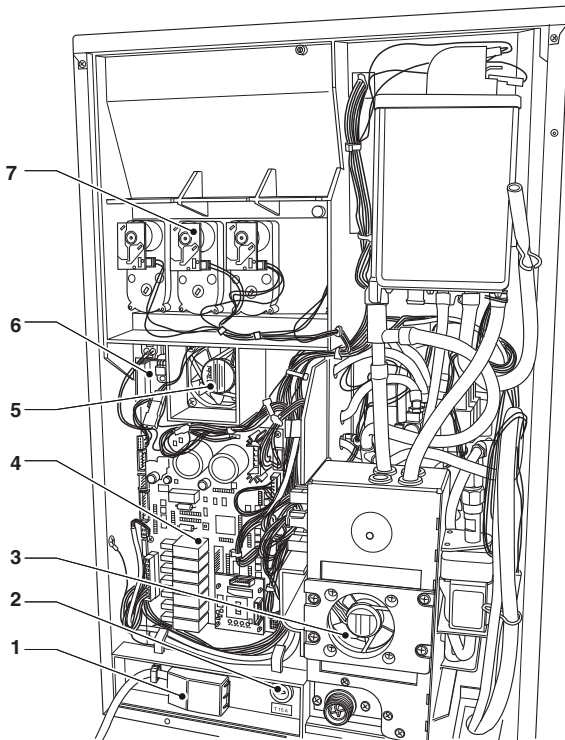

Fig. 32

- 1- Line lead terminal
- 2- Mains fuse
- 3- Waste compartment fan
- 4- Activation board
- 5- Fan
- 6- Boiler control board
- 7- Ingredient motors

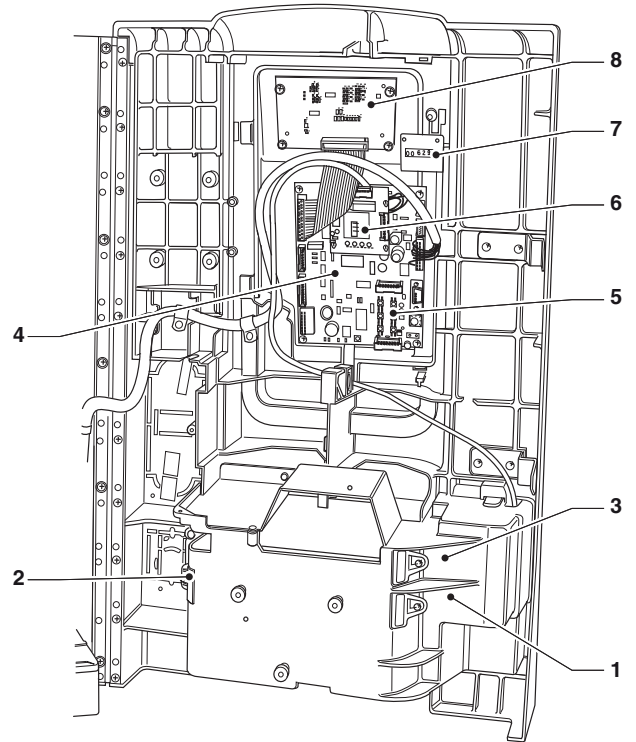

Fig. 33

- 1- Cup sensor (optional)
- 2- Reflector
- 3- Unit lighting LED board (optional)
- 4- CPU board
- 5- Service buttons
- 6- Coin mech interface board (optional)
- 7- Mechanical strokes counter
- 8- Graphic display board

SOFTWARE UPDATE

The machine is equipped with Flash EPROM which can be rewritten.

By means of an appropriate programme and a suitable system (PC or PDA) it is possible to rewrite the management software of the machine without replacing the EPROMs.

ACTIVATION BOARD

This board activates, through relays, the equipment working and the DC motors.

It manages the signals originating from the cams and/or microswitches on the various equipment. Furthermore, it controls the boiler management board. The board works with 24 Vdc for the electronic parts and the payment systems.

The board management software is loaded directly, (through RS232) on the microprocessor.

- The green LED 6 (23) flashes during the normal operation of the board;
- The yellow LED 7 (25) indicates the presence of 5 Vdc.
- The red LED 8 (12) is on during the board reset
- The red LED 4 (17) indicates the operating status of the espresso boiler resistance.
- The red LED 5 (18) **not used** on these models, indicates the operating status of the instant drinks boiler resistance.
- The green LED 1 (26) indicates the pulses of the volumetric counter.
- The green LED 2 (1) indicates the presence of 34Vdc.
- The green LED 3 (4) indicates the presence of regulated 34Vdc.

RELAY FUNCTION (SEE THE WIRING DIAGRAM)

Relay	=	User
RL1	=	EEA
RL2	=	MAC
RL3	=	Not used
RL4	=	Not used
RL5	=	Not used
RL6	=	PM
RL7	=	ESC

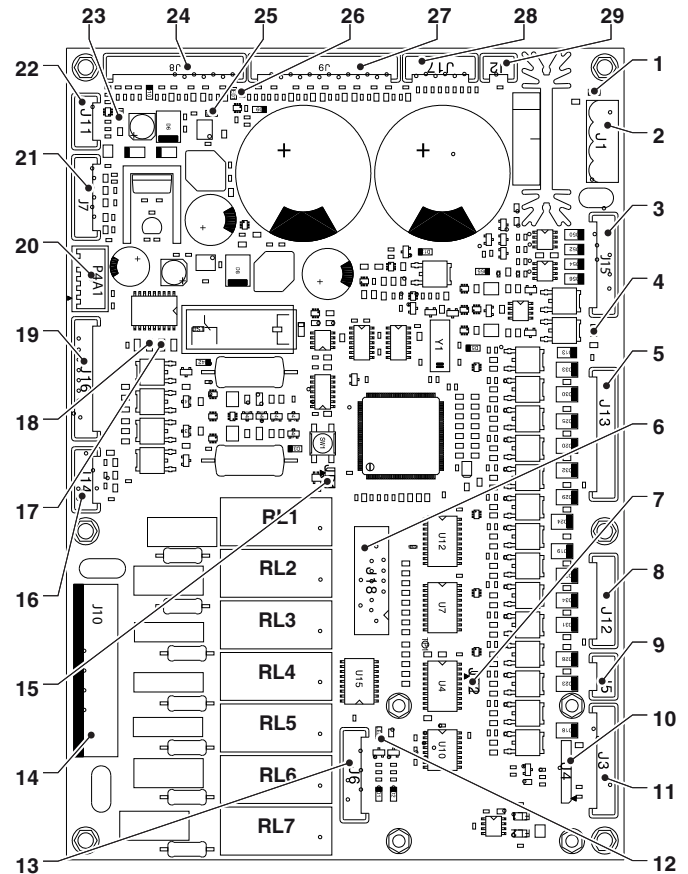

Fig. 34

- 1- LED 2
- 2- (J1) 24 Vdc power supply
- 3- (J15) Actuators in DC
- 4- LED 3
- 5- (J13) Solenoid valve - mixer motors
- 6- Not installed
- 7- JP2 Closed Jumper CAN
- 8- (J12) Motor-dispensers
- 9- (J5) CAN BUS
- 10- Connector for expansion board for payment systems (optional)
- 11- (J3) To the CPU board
- 12- LED 8
- 13- (J6) Board programming
- 14- (J10) Actuators
- 15- JP1 closed
- 16- (J14) Infuser unit motor
- 17- LED 4
- 18- LED 5
- 19- (J16) Not used
- 20- (P4A1) Not used
- 21- (J7) Not used
- 22- (J11) Safety microswitch
- 23- LED 6
- 24- (J8) Input
- 25- LED 7
- 26- LED 1
- 27- (J9) Input and volumetric counter
- 28- (J17) Probe and activation of boiler board
- 29- (J2) Not used

CPU BOARD

The CPU board (Central Process Unit) board controls the management of all the equipment and signals of the port.

The LEDs, during the operation, give the following indications:

- the green LED 3 (6) flashes during the normal operation of the CPU board;
- the yellow LED 1 (17) is on in the presence of 5 Vdc;
- the red LED 2 (15) is on when there is, for any reason, a reset of the software.

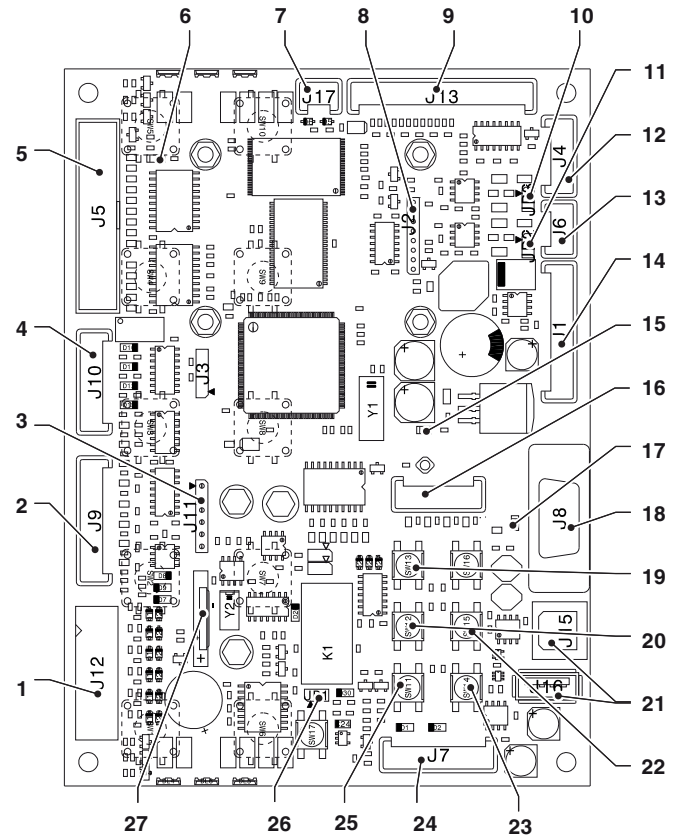

Fig. 35

- 1- (J12) Validators
- 2- (J9) Not used
- 3- (J11) RAM data expansion (optional)
- 4- (J10) Numeric selection keyboard (optional)
- 5- (J5) Graphic display
- 6- LED 3 "RUN"
- 7- (J17) Stroke counter
- 8- (J2) Expansion connector for serial payment systems
- 9- (J13) Photocell and area light
- 10- JP3 not used
- 11- Jumper CAN BUS JP2 (closed)
- 12- (J4) Not used
- 13- (J6) Not used
- 14- (J1) To the activation board
- 15- LED 2 "RESET"
- 16- Connector for UpKey
- 17- LED 1 "+5V"
- 18- (J8) RS232 Serial
- 19- Programmable button
- 20- Programmable button
- 21- not installed
- 22- Programmable button
- 23- Programmable button
- 24- (J7) Programming connector
- 25- Programming input button
- 26- (JP1) WatchdogINPUT JUMPER (Closed)
- 27- Battery

POWER SUPPLY BOARD

The board provides power supply to the control electronics of the machine.

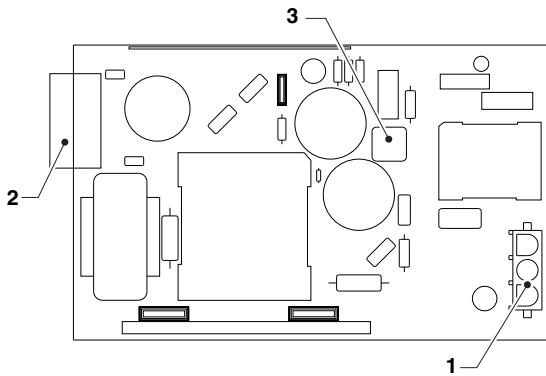

Fig. 36

- 1- (J1) power supply connector 120 V~
- 2- (J2) 24V connector
- 3- (J7) closed jumper

The power supply is located in the electrical panel and is accessible by removing the cover

Important!

The cover must be removed after disconnecting the device from the power supply.

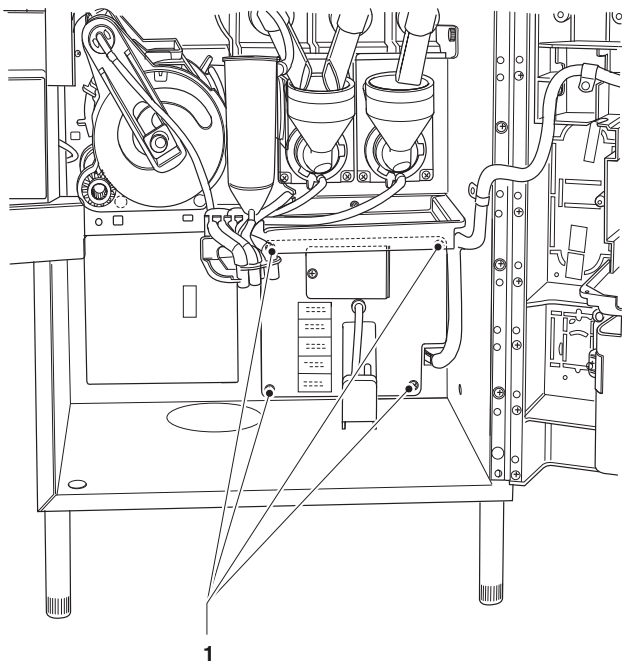

Fig. 37

- 1- Fixing screws

BOILER CONTROL BOARD

The board controls the intervention of the espresso boiler resistance.

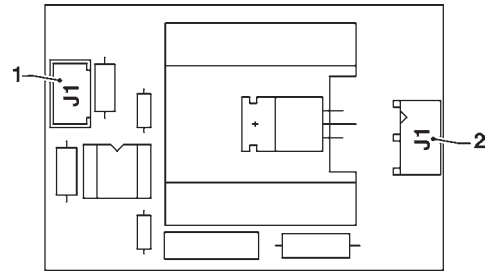

Fig. 38

- 1- (J1) To the activation board
- 2- (J2) To the boiler heating element

EXPANSION BOARD FOR PAYMENT SYSTEMS

This board is supplied together with the connection kit for the serial payment systems (optional).

By following the instructions included in the kit, install the board on the CPU board in case of payment systems fitted on the port.

In case of payment systems installed in the cabinet, this card is installed on the activation board

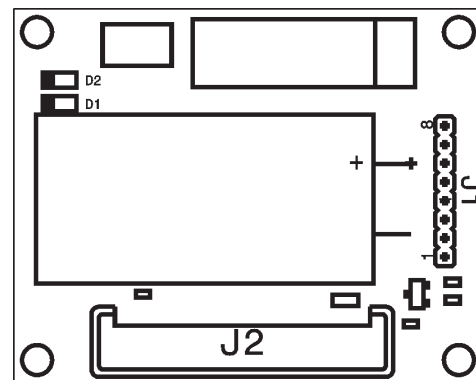
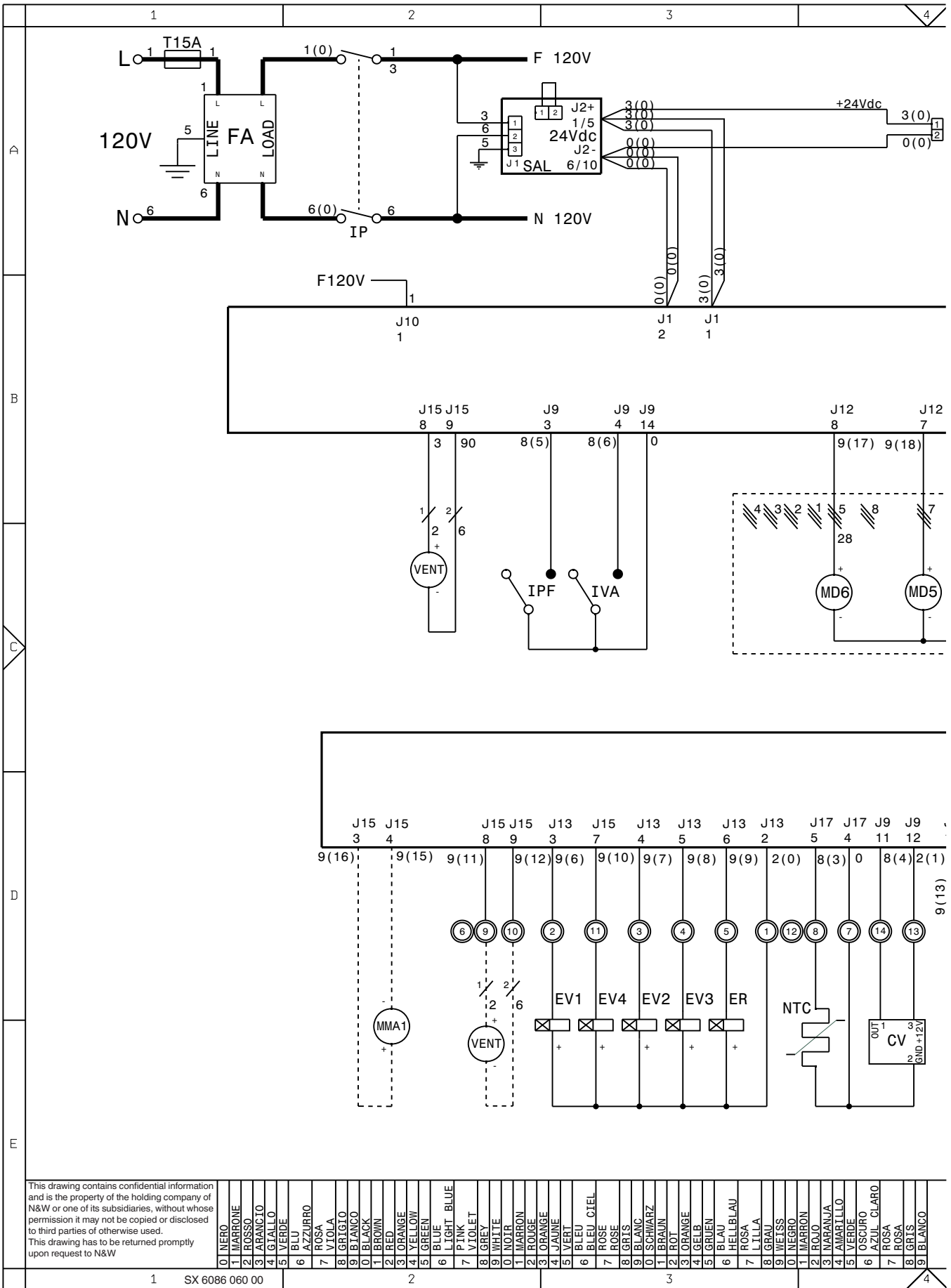

Fig. 39

- 1- (J1) To the activation board or CPU
- 2- (J2) To the payment system

WIRING DIAGRAMS

HYDRAULIC CIRCUIT



CM MOTOR CAM
 CV VOLUMETRIC COUNTER
 EEA WATER INLET SOLENOID VALVE
 ER COFFEE DISPENSING SOLENOID VALVE
 ESC COFFEE RELEASE ELECTROMAGNET
 EV1-.. INSTANT SOLENOID VALVES
 FA RADIO INTERFERENCE SUPPRESSOR
 ICM MOTOR CONTROL SWITCH
 ID COFFEE DOSE SWITCH

IP DOOR SWITCH
 IPF FULL WASTE SWITCH
 IVA EMPTY WATER SWITCH
 KC1-.. COFFEE BOILER CUTOFF
 KS1-2 SAFETY CUTOFF
 KS3-4 SAFETY CUTOFF
 M COFFEE UNIT MOTOR
 MAC GRINDER
 MD1-.. INGREDIENT MOTORS

3(0)
0(0) 24Vdc MDB

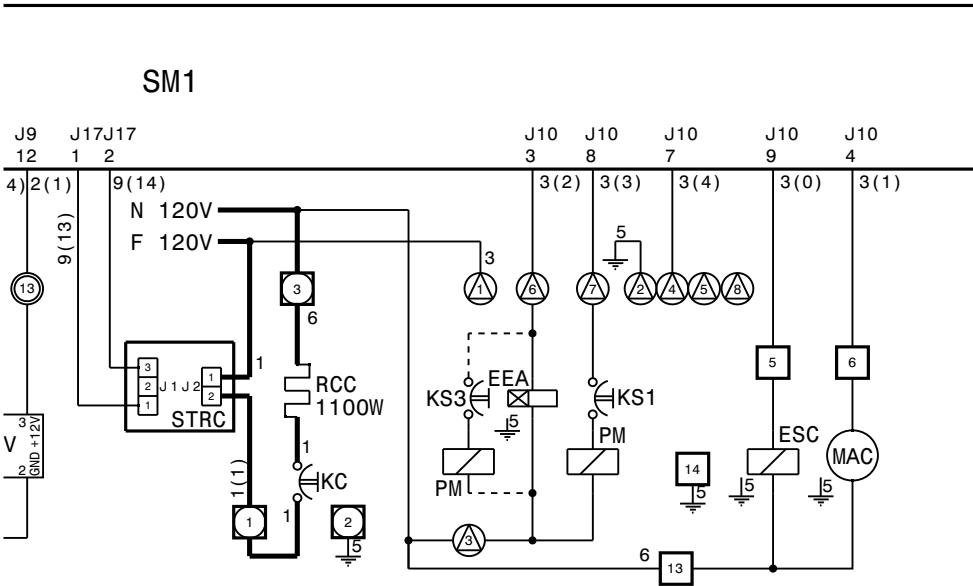
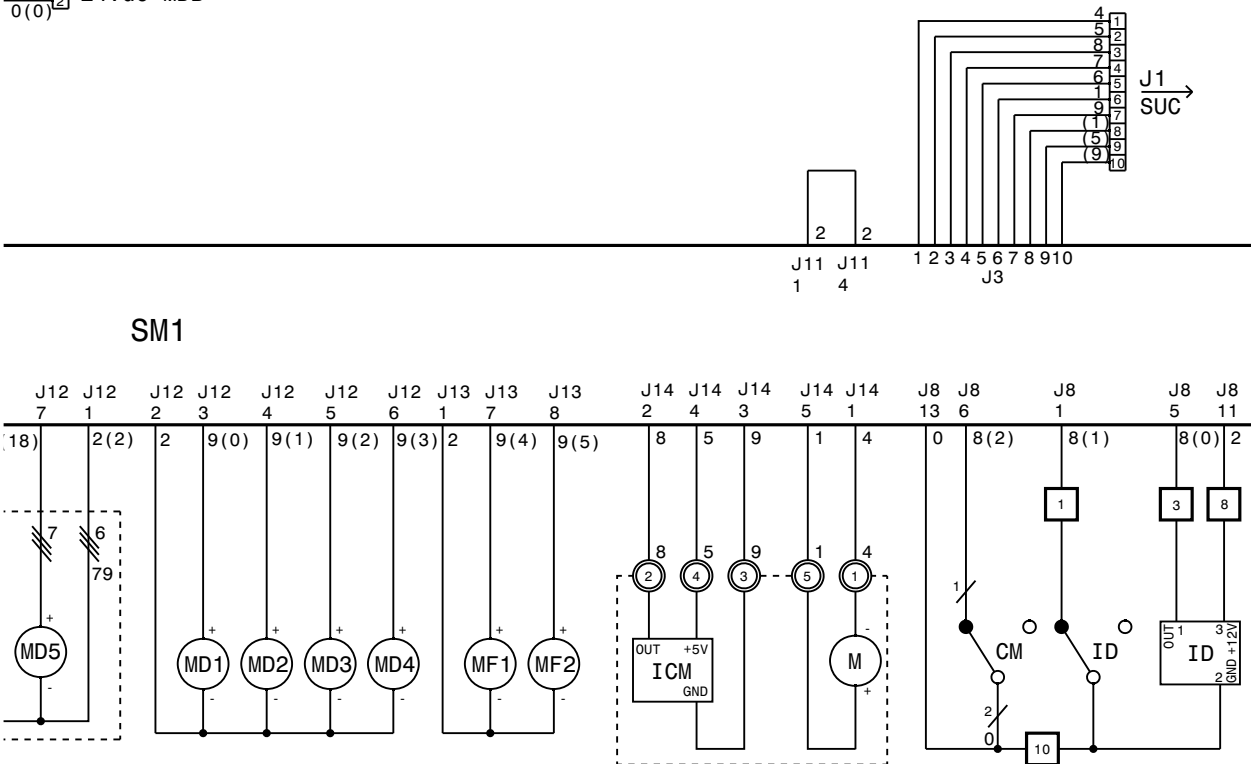

1 MUSA 8 GRIS 9 BELANNO	N&W GLOBAL VENDING S.p.A.	MODEL Krea UL 120V	DEFINITION SCHEMA ELETTRICO - WIRING DIAGRAM	DATE 22/05/2013	SHEET 1/1	PREPARED BONACINA	CHECKED BORLOTTI
	Valbrembo - Italia		MACCHINA - MACHINE	LEGENDA -	PART NUMBER 608606000		VERSTON
	4	5	6	7			

- MDTE- FRESH TEA INGREDIENT MOTOR
- MDZ SUGAR INGREDIENT MOTOR
- MF1-.. WHIPPER MOTORS
- MMA1- GRINDER ADJUSTING MOTOR
- NTC TEMPERATURE PROBE
- PM PUMP
- RCC COFFEE BOILER HEATING ELEMENT
- SAL VOLTAGE SUPPLY BOARD
- SM1 CONTROL BOARD

- STRC1 BOILER HEATING TRIAC BOARD
- SUC C.P.U. BOARD
- TX.... DELAYED FUSE (X=CURRENT)
- VENT FAN

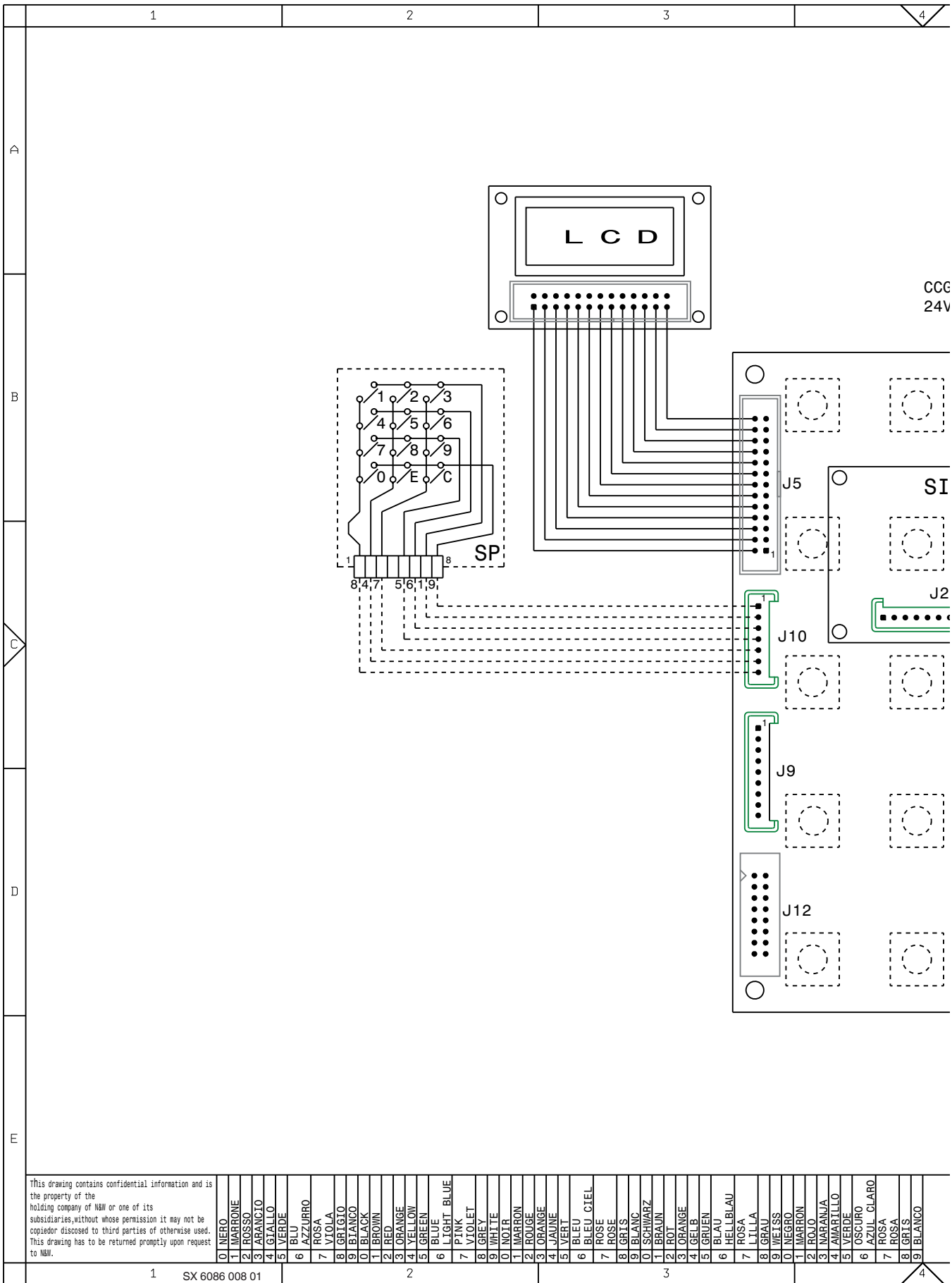

BDV BDV COIN MECH CONNECTOR
 CCG GENERAL COUNTER
 EX EXECUTIVE COIN MECH CONNECTORS

LCD LIQUID CRYSTAL DISPLAY
 SIG INTERFACE COIN MECHANISM P.C. BOARD
 SLED LED BOARD

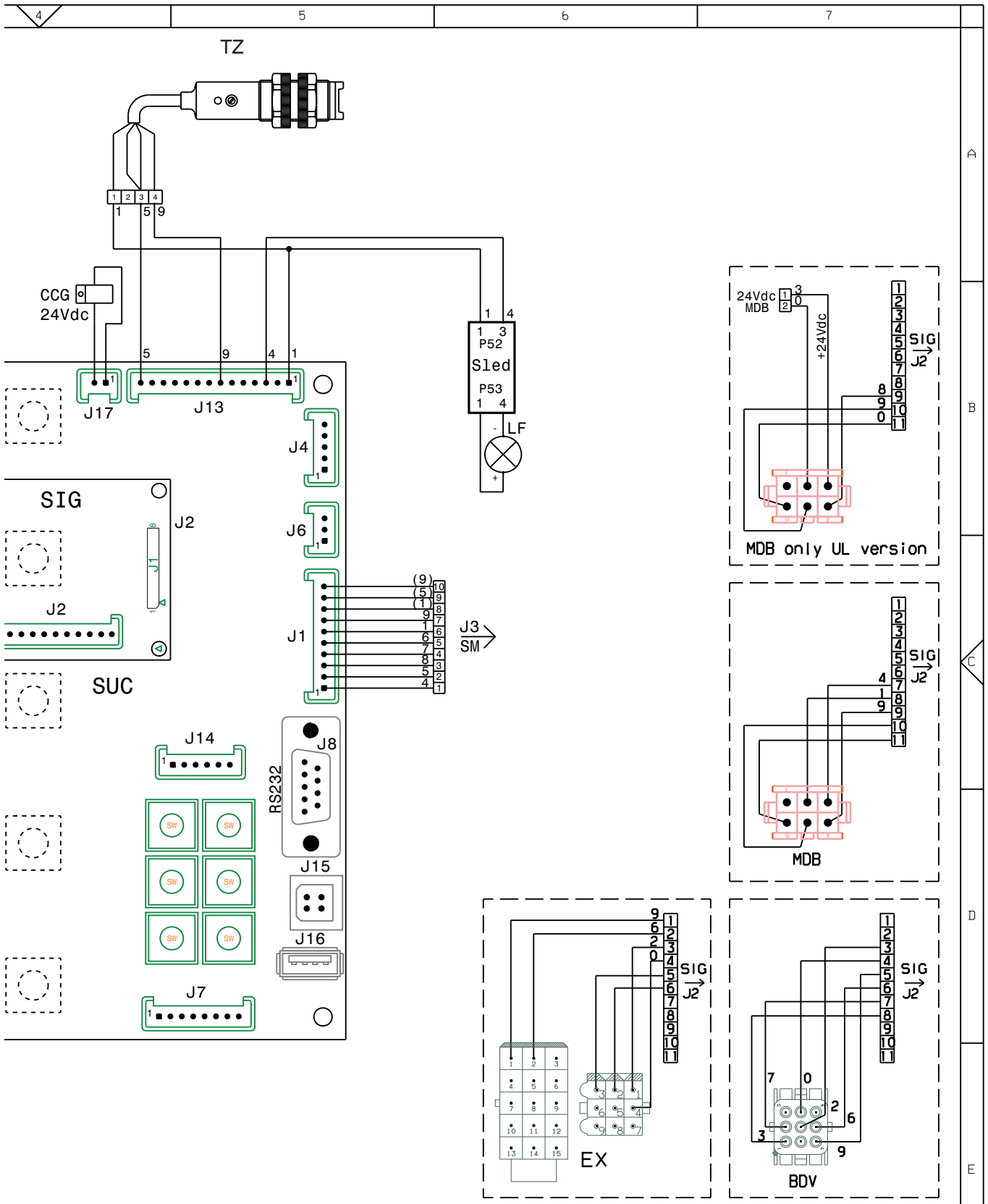

ROSA GRIS BLANCO	N&W GLOBAL VENDING S.p.A. Valbrembo - Italia	MODEL SOLISTA KREA	DEFINITION SCHEMA ELETTRICO - WIRING DIAGRAM PORTA - DOOR	DATE 09/12/2008	SHEET 1 / 1	PREPARED BONACINA	CHECKED MONGUZZI
				LEGENDA -	PART NUMBER 608600801		VERSION

SM CONTROL BOARD
 SP BUTTON BOARD

SUC C.P.U. BOARD
 TZ CUP SENSOR

HYDRAULIC CIRCUIT

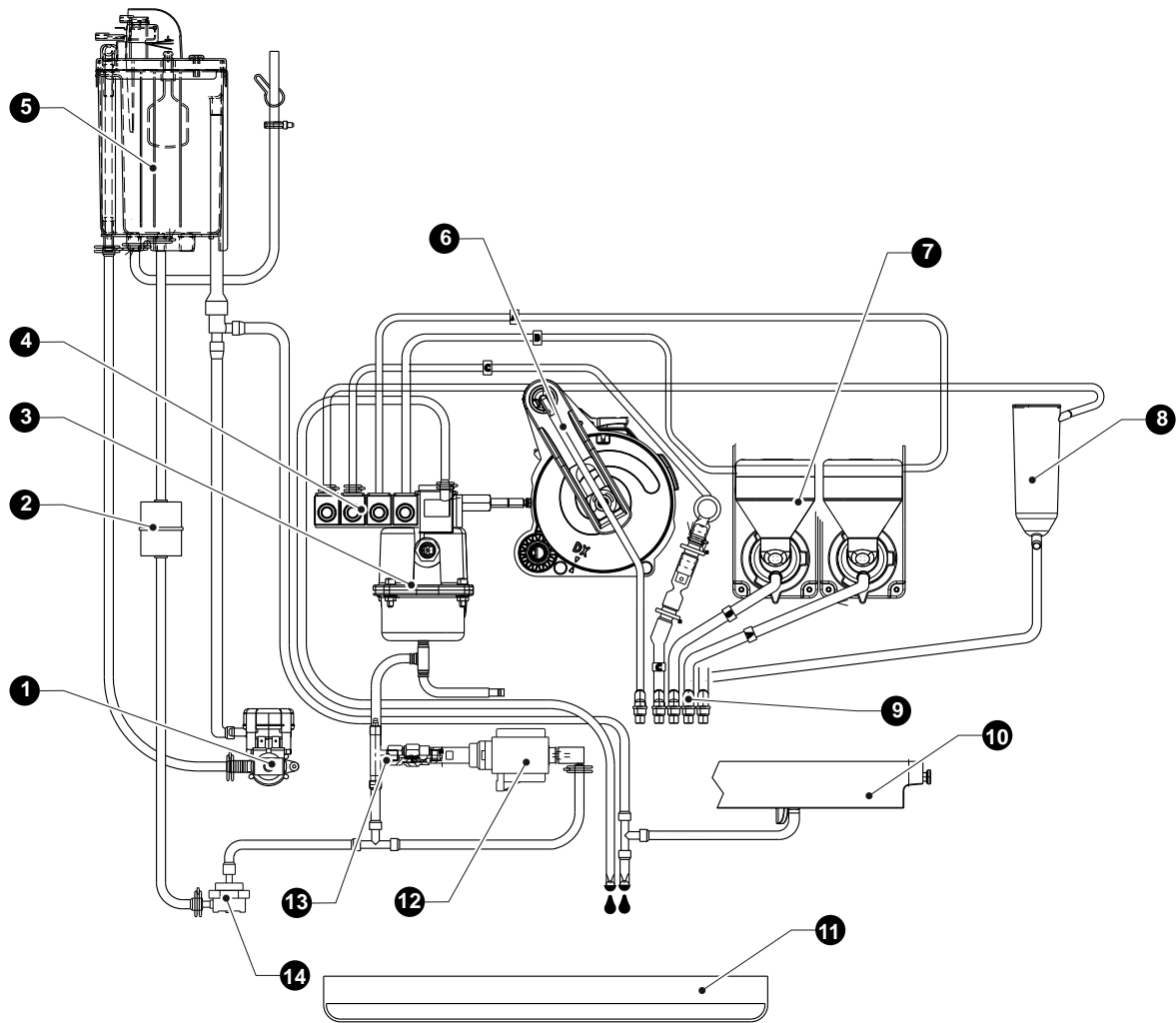

- 1- WATER INLET SOLENOID VALVE
- 2- MECHANICAL FILTER
- 3- BOILER
- 4- SOLENOID VALVE GROUP
- 5- AIR-BREAK
- 6- INFUSER UNIT
- 7- MIXER

- 8- EXPANSION NOZZLE
- 9- DISPENSING NOZZLES
- 10- MIXER CONTAINER
- 11- LIQUID RESIDUE CONTAINER
- 12- PUMP
- 13- BY-PASS
- 14- VOLUMETRIC COUNTER

NAVIGATION MODE

ENTERING THE PROGRAMMING MODE

The machine can work in 3 different operating modes:

- Normal user;
- Loader menu;
- Engineer menu.

For entering the programming menu you need to press the programming button.

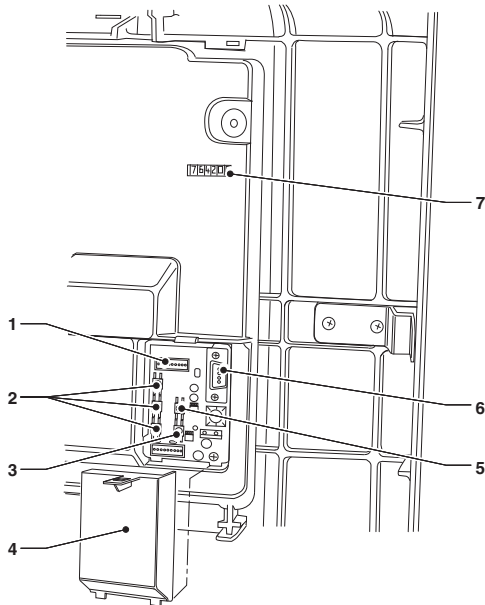

- 1- UpKey connector
- 2- Buttons with programmable function
- 3- Programming input button
- 4- Buttons cover
- 5- Faults reset button
- 6- RS232 serial connector
- 7- Mechanical stroke counter (if present)

The machine goes into Loader Menu mode. By pressing the key ← you can switch from the “Loader Menu” to the “Engineer Menu” and vice versa.

SURFING

If you want to move inside the menus use the keys shown in the figure:

NAVIGATION KEYS UP ↑ AND DOWN ↓

Through the navigation keys ↑ and ↓ it is possible to move from one item of the programming menus to the next which are at the same level and modify the status (ON/OFF) or the alphanumeric values of the functions

CONFIRMATION KEY / SEND ↵

Through the confirmation/send key ↵ it is possible to switch to the immediately lower-level menu or to confirm a data item which has just been entered or modified.

EXIT KEY ←

By pressing the exit key ← it is possible to go back to the upper level or exit from a function modification field. When you have reached the highest level of the Menu, by pressing this key again you can switch from the Engineer Menu to the Loader Menu and vice versa.

ENTERING THE ALPHANUMERIC VALUES

When the management software requests the input of numerical values, the keys assume the following functions:

- The confirmation key ↵ allows you to modify / enter the first character, confirm it and then go on to the next one.
- the keys ↑ and ↓ allow you to scroll the available characters.

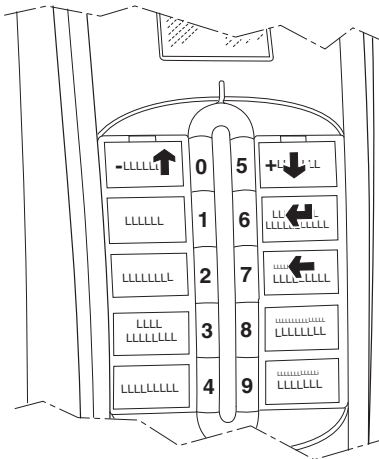

PASSWORD INPUT WITH CLOSED DOOR

The password input with closed door allows to perform the operation associated with the entered password. By means of the password input with closed door it is possible to:

- Wash the mixer
- Wash the infuser unit
- Reset the waste counter

To enter the password with closed door, proceed as follows:

- Press and hold key no. 4 for two seconds.
 - The management software requests the input of a password, the keyboard assumes the numeric values shown in the figure.
- The machine remains in standby for a few seconds for the input of the password (5 digits) which allows you to perform the operation associated with the entered password.

These passwords can be defined in the Engineer Menu. By default, all the passwords are disabled.

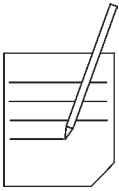

Four horizontal lines for writing, starting from the top of the page.

Twenty horizontal lines for writing, continuing down the page.

Four horizontal lines for writing.

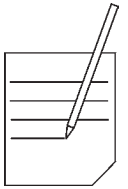

Twenty horizontal lines for writing, continuing from the first section.

The manufacturer reserves the right to modify, without prior notice, the characteristics of the equipment described in this publication; and further declines to accept any responsibility for any inaccuracies contained in this publication which can be ascribed to printing and /or transcription errors.

All instructions, drawings, tables and information contained in this publication are confidential and can neither be reproduced, completely or in part, nor be transmitted to third parties without the written permit of the Manufacturer, who has the sole ownership.

